

CONTROL FLOW, INC. PATENTS

NO.	PATENTS	COUNTRY	DATE
1	Automated Riser Recoil Control System and Method	United States	11/16/2004
2	Breach Block Connectors for Use With Oil Field Lines and Oil Field Equipment	United States	1/16/2007
3	Breach Block Connectors for Use With Oil Field Lines and Oil Field Equipment	Singapore	8/31/2007
4	Breach Block Connectors for Use With Oil Field Lines and Oil Field Equipment	Norwegian	9/21/2015
5	Breach Block Connectors for Use With Oil Field Lines and Oil Field Equipment	Brazilian	2/23/2021
6	Choke and Kill Line Systems for Blowout Preventers	European	12/29/2004
7	Choke and Kill Line Systems for Blowout Preventers	United States	5/9/2006
8	Choke and Kill Line Systems for Blowout Preventers	Singapore	12/29/2006
9	Choke and Kill Line Systems for Blowout Preventers	Brazilian	6/30/2015
10	Choke and Kill Line Systems for Blowout Preventers	Norwegian	7/13/2015
11	Co-Linear Tensioner and Methods for Assembling Production and Drilling Risers Using Same	Norwegian	11/15/2002
12	Co-Linear Tensioner and Methods for Assembling Production and Drilling Risers Using Same	European	11/29/2002
13	Co-Linear Tensioner and Methods for Assembling Production and Drilling Risers Using Same	United States	4/29/2003
14	Co-Linear Tensioner and Methods for Assembling Production and Drilling Risers Using Same	Singapore	12/30/2005
15	Co-Linear Tensioner and Methods for Assembling Production and Drilling Risers Using Same	Brazil	1/21/2015
16	Co-Linear Tensioner and Methods of Installing and Removing Same	United States	3/4/2008
17	Hydropneumatic Cable Tensioner	United States	9/10/1985
18	Linear Pipe Recovery/Lay Tensioners & Methods of Using Same	Singapore	1/21/2013
19	Linear Pipe Recovery/Lay Tensioners & Methods of Using Same	United States	9/2/2014
20	Linear Pipe Recovery/Lay Tensioners & Methods of Using Same	United States	6/6/2017
21	Linear Pipe Recovery/Lay Tensioners & Methods of Using Same	European	10/16/2019

CONTROL FLOW, INC. PATENTS

NO.	PATENTS	COUNTRY	DATE
22	Linear Pipe Recovery/Lay Tensioners & Methods of Using Same	Brazilian	12/8/2020
23	Metal-To-Metal Well Equipment Seal	United States	6/15/2021
24	Metal-To-Metal Well Equipment Seal	Mexican	3/21/2023
25	Metal-To-Metal Well Equipment Seal	United States	5/16/2023
26	Pipe Roller Assembly	United States	1/8/2009
27	Pipe Roller Assembly	United States	10/19/2010
28	Pipe Roller Assembly	Singapore	3/15/2011
29	Pipe Roller Assembly	European	2/17/2021
30	Portable Drill String Compensator	Norwegian	11/28/2003
31	Portable Drill String Compensator	United States	11/29/2005
32	Portable Drill String Compensator	Singapore	8/31/2006
33	Portable Drill String Compensator	United States	11/7/2006
34	Portable Drill String Compensator	Brazil	2/21/2017
35	Portable Heave Compensator	European	11/19/2003
36	Ram-Type Tensioner Assembly Having Integral Hydraulic Fluid Accumulator	Norwegian	11/28/2003
37	Ram-Type Tensioner Assembly Having Integral Hydraulic Fluid Accumulator	European	12/8/2003
38	Ram-Type Tensioner Assembly Having Integral Hydraulic Fluid Accumulator	United States	3/7/2006
39	Ram-Type Tensioner Assembly Having Integral Hydraulic Fluid Accumulator	Singapore	10/31/2006
40	Ram-Type Tensioner Assembly Having Integral Hydraulic Fluid Accumulator	United States	11/7/2006
41	Ram-Type Tensioner Assembly Having Integral Hydraulic Fluid Accumulator	Brazil	1/13/2015
42	System and Method for Riser Recoil Control	United States	12/28/2004

**CONTROL FLOW, INC.
PATENTS**

NO.	PATENTS	COUNTRY	DATE
43	Tensioner/Slip-Joint Assembly	Norwegian	6/14/2001
44	Tensioner/Slip-Joint Assembly	United States	5/25/2004
45	Tensioner/Slip-Joint Assembly	United States	3/11/2003
46	Tensioner/Slip-Joint Assembly	Singapore	1/31/2005
47	Tensioner/Slip-Joint Assembly	European	3/29/2006
48	Tensioner/Slip-Joint Assembly	Brazil	9/6/2011
49	Tensioner/Slip-Joint Assembly	European	3/29/2006
50	Tensioner/Slip-Joint Assembly	Brazil	1/13/2015
51	Weight Set Mandrel and Tubing Hanger	United States	12/18/2018
52	Weight Set Mandrel and Tubing Hanger	European	7/28/2021



US006817422B2

(12) **United States Patent**
Jordan

(10) **Patent No.:** US 6,817,422 B2
(45) **Date of Patent:** Nov. 16, 2004

(54) **AUTOMATED RISER RECOIL CONTROL SYSTEM AND METHOD**

(58) **Field of Search** 166/355, 335, 166/352, 381; 175/5, 7, 27, 85

(75) **Inventor:** Larry Russell Jordan, Houston, TX (US)

(56) **References Cited**

(73) **Assignee:** Cooper Cameron Corporation, Houston, TX (US)

U.S. PATENT DOCUMENTS

(*) **Notice:** Subject to any disclaimer, the term of this patent is extended or adjusted under 35 U.S.C. 154(b) by 3 days.

3,653,635 A	4/1972	Bates, Jr. et al.	
4,121,806 A	10/1978	Iato et al.	254/172
4,351,261 A	9/1982	Shanks	114/264
4,432,420 A	2/1984	Gregory et al.	166/355
4,466,488 A	8/1984	Naylor et al.	166/355
4,487,150 A	12/1984	Shanks	114/264
4,501,219 A	2/1985	Bates, Jr.	114/264
4,638,978 A	1/1987	Jordan	254/228
4,759,256 A	7/1988	Kovit et al.	91/29
4,962,817 A	10/1990	Jones et al.	175/166
5,209,302 A	5/1993	Robichaux et al.	166/355

(21) **Appl. No.:** 10/276,411

(22) **PCT Filed:** May 15, 2001

(86) **PCT No.:** PCT/US01/15623

§ 371 (c)(1),
(2), (4) **Date:** Nov. 14, 2002

(87) **PCT Pub. No.:** WO01/88323

PCT Pub. Date: Nov. 22, 2001

(65) **Prior Publication Data**

US 2003/0205383 A1 Nov. 6, 2003

Related U.S. Application Data

(60) **Provisional application No. 60/204,442, filed on May 15, 2000.**

(51) **Int. Cl.⁷** E21B 19/00; E21B 23/00

(52) **U.S. Cl.** 166/381; 166/355; 175/7; 175/27

Primary Examiner—David Bagnell

Assistant Examiner—Jennifer Gay

(74) *Attorney, Agent, or Firm*—Michael P. Hartmann; Peter J. Bielinski

(57) **ABSTRACT**

An automated riser recoil control system (10) including a plurality of riser tensioners (20), a vessel heave measurement system (210) and a control processor (70) with each tensioner (20) having a piston travel indicator (27) which signals the processor (70) and a method of operation is disclosed.

15 Claims, 4 Drawing Sheets

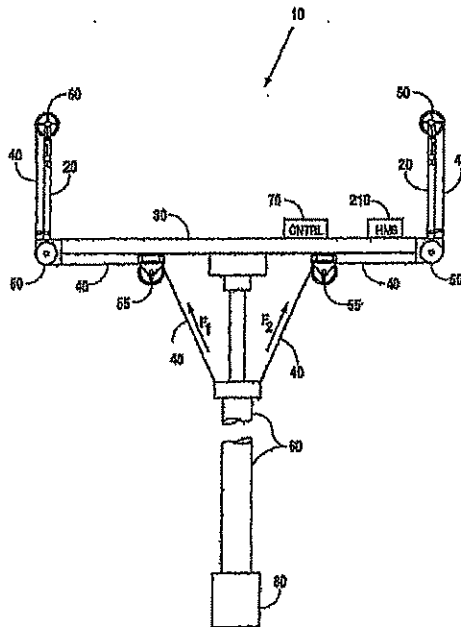



US007163054B2

(12) **United States Patent**
Adams

(10) **Patent No.:** **US 7,163,054 B2**
(45) **Date of Patent:** **Jan. 16, 2007**

(54) **BREECHBLOCK CONNECTORS FOR USE WITH OIL FIELD LINES AND OIL FIELD EQUIPMENT**

(75) **Inventor:** James Murph Adams, Cypress, TX (US)

(73) **Assignee:** Control Flow Inc., Houston, TX (US)

(*) **Notice:** Subject to any disclaimer, the term of this patent is extended or adjusted under 35 U.S.C. 154(b) by 170 days.

(21) **Appl. No.:** 10/827,653

(22) **Filed:** Apr. 19, 2004

(65) **Prior Publication Data**
US 2004/0256096 A1 Dec. 23, 2004

Related U.S. Application Data

(63) Continuation-in-part of application No. 10/601,946, filed on Jun. 23, 2003, now Pat. No. 7,040,393.

(51) **Int. Cl.**
E21B 17/02 (2006.01)

(52) **U.S. Cl.** 166/75.13; 166/242.6; 285/18

(58) **Field of Classification Search** 166/360, 166/380, 382, 75.13, 242.6; 285/18
See application file for complete search history.

(56) **References Cited**

U.S. PATENT DOCUMENTS

3,421,580 A 1/1969 Fowler et al.

3,442,536 A	5/1969	Fowler	
3,800,869 A	4/1974	Herd et al.	
3,895,829 A	7/1975	Manson, Jr.	
3,948,545 A	4/1976	Bonds	
4,165,891 A	8/1979	Sullaway et al.	
4,185,856 A *	1/1980	McCaskill	285/18
4,209,191 A	6/1980	Lawson	
4,290,482 A *	9/1981	Brisco	166/75.13
4,540,053 A *	9/1985	Baugh et al.	166/382
4,807,705 A	2/1989	Henderson et al.	
5,069,288 A *	12/1991	Singeeham	166/382

FOREIGN PATENT DOCUMENTS

GB	260140	10/1926
GB	2 114 631 A	8/1983

* cited by examiner

Primary Examiner—David Bagnell

Assistant Examiner—Matthew J. Smith

(74) *Attorney, Agent, or Firm*—Bracewell & Giuliani LLP; Anthony F. Matheny

(57) **ABSTRACT**

The invention is directed to breechblock connections to and between oil field equipment and oil field lines for use with oil field equipment associated with oil and gas exploration, drilling, and production. The oil field lines and oil field equipment of the invention include a breechblock connection for quick and easy removal and installation of the oil field lines to oil field equipment and to other oil field lines, and connections between different pieces of oil field equipment. Methods of connecting lines to oil field equipment and connecting one piece of oil field equipment to a second piece of oil field equipment are also disclosed.

29 Claims, 7 Drawing Sheets

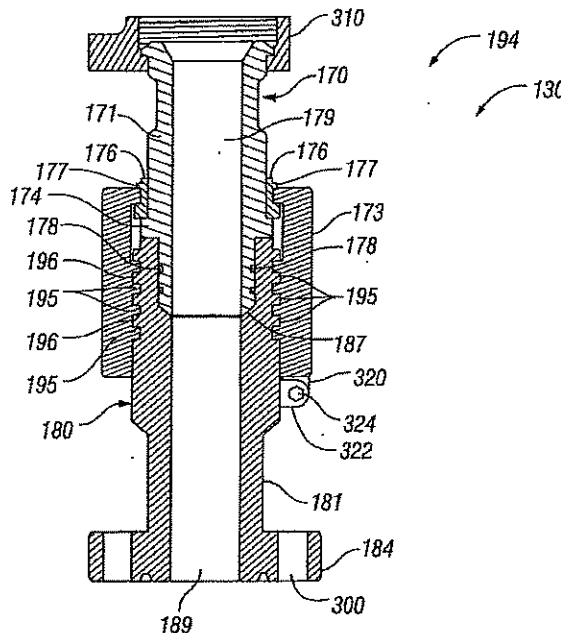

**THE REGISTRY OF PATENTS
SINGAPORE**

THE PATENTS ACT
(CHAPTER 221)

CERTIFICATE OF GRANT OF PATENT

In accordance with section 35 of the Patents Act, it is hereby certified that a patent having the P-No. 116624 has been granted in respect of an invention having the following particulars:

Title : BREECHBLOCK CONNECTORS FOR USE WITH
OIL FIELD LINES AND OIL FIELD EQUIPMENT

Application Number : 200502347-8

Date of Filing : 18 April 2005

Priority Data : 19 April 2004 - PATENT APPLICATION NO.
10/827,653 (UNITED STATES OF AMERICA)

Name of Inventor(s) : JAMES M. ADAMS

Name(s) and Address(es) of
Proprietor(s) of Patent : CONTROL FLOW INC.
9201 FAIRBANKS NORTH HOUSTON ROAD
HOUSTON,
TEXAS 77064
UNITED STATES OF AMERICA

Date of Grant : 31 August 2007

Dated this 31st day of August 2007



Chiam Lu Lin (Ms)
Deputy Registrar of Patents,
Singapore.

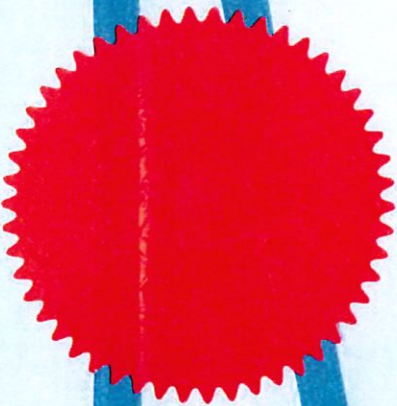



(12) PATENT

(19) NO

(11) 336548

(13) B1

NORGE

(51) Int Cl.

F16L 23/00 (2006.01)
E21B 33/036 (2006.01)
E21B 33/064 (2006.01)
E21B 33/076 (2006.01)

✓Breechblock Connectors for use with Oil Field Lines and Oil Field Equipment

Patentstyret

(21)	Søknadsnr	20051701	(86)	Int.inng.dag og søknadsnr	
(22)	Inng.dag	2005.04.06	(85)	Videreføringsdag	
(24)	Løpedag	2005.04.06	(30)	Prioritet	2004.04.19, US, 827653
(41)	Alm.tilgj	2005.10.20			
(45)	Meddelt	✓ 2015.09.21			
(73)	Innehaver	Control Flow Inc, 9201 Fairbanks North Houston Road, US-TX77064 HOUSTON, USA			
(72)	Oppfinner	James M Adams, 12418 Winding Lane, US-TX77429 CYPRESS, USA			
(74)	Fullmektig	Tandbergs Patentkontor AS, Postboks 1570 Vikta, 0118 OSLO, Norge			

(54) Benevnelse **Koplingsystem for tilkopling av ledninger til utrustning på oljefelt**

(56) Anførte publikasjoner
GB 2114631 A
US 5069288 A
US 4540053 A

(57) Sammendrag

Oppfinnelsen retter seg mot låseblokkkoblinger til og mellom oljefeltutstyr og oljefeltledninger for bruk med oljefeltutstyr forbundet med olje og gassutforskning, boring og produksjon. Oljefeltledningene og oljefeltutstyret ifølge oppfinnelsen omfatter en låseblokkobling for hurtig og enkel fjerning og installasjon av oljefeltledninger til oljefeltutstyret og til andre oljefeltledninger, og tilkoblinger mellom ulike deler oljefeltutstyr. Fremgangsmåter for å tilkoble ledninger til oljefeltutstyr og tilkobling av en del av oljefeltutstyr til en andre del av oljefeltutstyr er også omtalt.

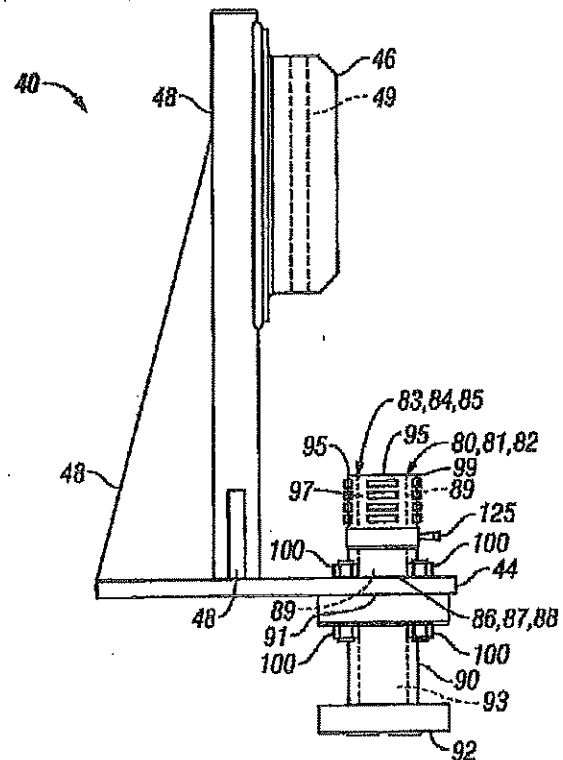



REPÚBLICA FEDERATIVA DO BRASIL
MINISTÉRIO DA ECONOMIA
INSTITUTO NACIONAL DA PROPRIEDADE INDUSTRIAL

CARTA PATENTE Nº PI 0503005-6

O INSTITUTO NACIONAL DA PROPRIEDADE INDUSTRIAL concede a presente PATENTE DE INVENÇÃO, que outorga ao seu titular a propriedade da invenção caracterizada neste título, em todo o território nacional, garantindo os direitos dela decorrentes, previstos na legislação em vigor.

(21) Número do Depósito: PI 0503005-6

(22) Data do Depósito: 15/04/2005

(43) Data da Publicação Nacional: 06/12/2005

(51) Classificação Internacional: E21B 7/12.

(30) Prioridade Unionista: US 10/827,653 de 19/04/2004.

(54) Título: CONEXÕES DE BLOCO DE CULATRA PARA USO COM LINHAS DE CAMPO DE PETRÓLEO E EQUIPAMENTO DE CAMPO DE PETRÓLEO

(73) Titular: CONTROL FLOW, INC, Empresa Norte Americana. Endereço: 9201 Fairbanks North Houston Road, Houston, Texas 77064, ESTADOS UNIDOS DA AMÉRICA(US)

(72) Inventor: JAMES MURPH ADAMS.

Prazo de Validade: 10 (dez) anos contados a partir de 23/02/2021, observadas as condições legais

→ Expedida em: 23/02/2021

Assinado digitalmente por:

Liane Elizabeth Caldeira Lage

Diretora de Patentes, Programas de Computador e Topografias de Circuitos Integrados

(Breach Block Connectors for use with oil field lines & oil field equipment)

(19)



(11)

EP 1 491 717 B1

(12)

EUROPEAN PATENT SPECIFICATION

(45) Date of publication and mention of the grant of the patent:
03.10.2007 Bulletin 2007/40

(51) Int Cl.:
E21B 33/038^(2006.01) E21B 33/06^(2006.01)

(21) Application number: **04076680.0**

(22) Date of filing: **08.06.2004**

(54) **Choke and kill line systems for blowout preventers**

Choke und Kill-Leitungen System für ein Backenausbruchsventil

System de connecteur de conduite d'injection pour un obturateur anti-éruption

(84) Designated Contracting States:
FI FR GB NL RO

• **Curtiss, Jason P. III**
Houston,
Texas 77065 (US)

(30) Priority: **23.06.2003 US 601946**

(74) Representative: **Newstead, Michael John et al**
Page Hargrave
Southgate
Whitefriars
Lewins Mead
Bristol BS1 2NT (GB)

(43) Date of publication of application:
 - **29.12.2004 Bulletin 2004/53**

(73) Proprietor: **Control Flow Inc.**
Houston, TX 77064 (US)

(72) Inventors:
 • **Adams, James M.**
Cypress,

Texas 77429 (US)

(56) References cited:
US-A- 4 668 126 US-A- 6 089 321
US-A1- 2003 024 705 US-A1- 2003 136 927
US-B1- 6 470 975

EP 1 491 717 B1

Note: Within nine months from the publication of the mention of the grant of the European patent, any person may give notice to the European Patent Office of opposition to the European patent granted. Notice of opposition shall be filed in a written reasoned statement. It shall not be deemed to have been filed until the opposition fee has been paid. (Art. 99(1) European Patent Convention).



US007040393B2

(12) **United States Patent**
Adams et al.

(10) **Patent No.: US 7,040,393 B2**
(45) **Date of Patent: May 9, 2006**

(54) **CHOKE AND KILL LINE SYSTEMS FOR BLOWOUT PREVENTERS**

4,668,126 A 5/1987 Burton
4,807,705 A 2/1989 Henderson et al.
4,848,472 A 7/1989 Hopper

(75) **Inventors: James M. Adams, Cypress, TX (US); Jason P. Curtiss, III, Houston, TX (US)**

(Continued)

(73) **Assignee: Control Flow Inc., Houston, TX (US)**

RetroSearch Search Results with Abstracts, Mar. 24, 2003, pp. 1-8.

(*) **Notice: Subject to any disclaimer, the term of this patent is extended or adjusted under 35 U.S.C. 154(b) by 204 days.**

Primary Examiner—Jennifer H. Gay
Assistant Examiner—Matthew J. Smith
(74) *Attorney, Agent, or Firm*—Andrews Kurth LLP; Anthony F. Matheny

(21) **Appl. No.: 10/601,946**

(22) **Filed: Jun. 23, 2003**

(57) **ABSTRACT**

(65) **Prior Publication Data**

US 2004/0256107 A1 Dec. 23, 2004

(51) **Int. Cl.**
E21B 23/02 (2006.01)

(52) **U.S. Cl. 166/77.51; 166/85.4; 166/85.5; 285/401; 285/391**

(58) **Field of Classification Search 166/77.51; 166/85.4, 85.5, 338, 344, 345, 368, 363; 285/124.4, 124.5, 360, 378, 401, 391**
See application file for complete search history.

The invention is directed to pressure lines for use with equipment associated with drilling and production risers, and in particular, pressure lines having breechblock connections with the equipment and with choke and kill lines for use in connection with different sized blowout preventer stacks ("BOP stacks"). The pressure line systems and choke and kill line systems of the invention include a breechblock connection for quick and easy removal and installation of the pressure lines to riser equipment and the choke and kill lines to BOP stacks. Additionally, the choke and kill lines of the invention may include a coupling system having a BOP connector, or plate assembly, for permitting one set of choke and kill lines to be used on various sized BOP stacks. The plate assembly is in fluid communication with a first choke or kill line connector. Each of the choke and kill lines, or hoses, include a second choke or kill line connector, preferably as part of a line assembly, which is capable of being releasably secured to the first choke or kill line connector. Therefore, by installing a plate assembly on different sized BOP stacks, one set of choke and kill lines can be used in connection with multiple sized BOP stacks. Methods of replacing BOP stacks and installing and removing choke and kill lines and pressure lines are also disclosed.

(56) **References Cited**

U.S. PATENT DOCUMENTS

3,688,840 A * 9/1972 Curington et al. 166/341
3,877,520 A 4/1975 Putnam
3,974,875 A * 8/1976 Herd et al. 166/367
4,053,023-A 10/1977 Herd et al.
4,210,208 A 7/1980 Shanks
4,319,637 A * 3/1982 Wilson 166/340
4,488,740 A 12/1984 Baugh et al.
4,540,053 A 9/1985 Baugh et al.
4,597,448 A 7/1986 Baugh
4,615,544 A 10/1986 Baugh
4,618,314 A 10/1986 Hailey

26 Claims, 5 Drawing Sheets

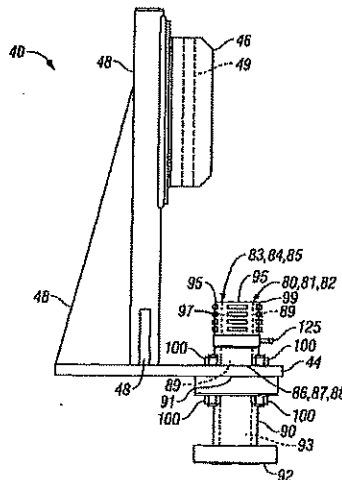

**THE REGISTRY OF PATENTS
SINGAPORE**

**THE PATENTS ACT
(CHAPTER 221)**

CERTIFICATE OF GRANT OF PATENT

In accordance with section 35 of the Patents Act, it is hereby certified that a patent having the P-No. 118286 has been granted in respect of an invention having the following particulars:

Title : CHOKE AND KILL LINE SYSTEMS FOR
BLOWOUT PREVENTERS

Application Number : 200404133-1

Date of Filing : 11 June 2004

Priority Data : 23 June 2003 - PATENT APPLICATION NO. US
10/601,946 (UNITED STATES OF AMERICA)

Name of Inventor(s) : JAMES M. ADAMS; JASON P. CURTISS, III

Name(s) and Address(es) of
Proprietor(s) of Patent : CONTROL FLOW INC.
9201 FAIRBANKS NORTH HOUSTON ROAD,
HOUSTON, TEXAS 77064.
UNITED STATES OF AMERICA

Date of Grant : 29 December 2006

Dated this 29th day of December 2006.

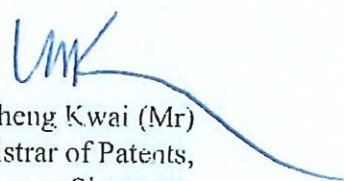
Wong Sheng Kwai (Mr)
Acting Registrar of Patents,
Singapore

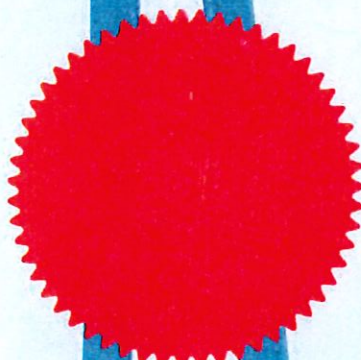



PI 04023951
PI 04023951
INPI
Assinado
Digitalmente

REPÚBLICA FEDERATIVA DO BRASIL
MINISTÉRIO DO DESENVOLVIMENTO, INDÚSTRIA E COMÉRCIO EXTERIOR
INSTITUTO NACIONAL DA PROPRIEDADE INDUSTRIAL

CARTA PATENTE Nº PI 0402395-1

O INSTITUTO NACIONAL DA PROPRIEDADE INDUSTRIAL concede a presente PATENTE DE INVENÇÃO, que outorga ao seu titular a propriedade da invenção caracterizada neste título, em todo o território nacional, garantindo os direitos dela decorrentes, previstos na legislação em vigor.

(21) Número do Depósito: PI 0402395-1

(22) Data do Depósito: 17/06/2004

(43) Data da Publicação do Pedido: 17/06/2005

(51) Classificação Internacional: F16L 55/00

(30) Prioridade Unionista: 23/06/2003 US 10/601,946

(54) Título: TUBULAÇÕES DE PRESSÃO PARA USO COM EQUIPAMENTO ASSOCIADO COM ELEVADORES DE PERFURAÇÃO E PRODUÇÃO

(73) Titular: CONTROL FLOW, INC., Endereço: 9201 Fairbanks North Houston Road, Houston, Texas 77064, Estados Unidos da América (US)

(72) Inventor: JAMES M. ADAMS; JASON P. CURTISS III

Prazo de Validade: 10 (dez) anos contados a partir de 30/06/2015, observadas as condições legais.

Expedida em: 30 de Junho de 2015

Assinado digitalmente por:

Júlio César Castelo Branco Reis Moreira
Diretor de Patentes

Choke and Kill Line Systems for Blowout Preventers



(12) PATENT

(19) NO

(11) 336291

(13) B1

NORGE

(51) Int Cl.

E21B 33/038 (2006.01)

E21B 33/064 (2006.01)

E21B 33/076 (2006.01)

Patentstyret

✓Choke and Kill Line Systems for Blowout Preventers

(21)	Søknadsnr	20042458	(86)	Int.inng.dag og søknadsnr	
(22)	Inng.dag	2004.06.14	(85)	Videreføringsdag	
(24)	Løpedag	2004.06.14	(30)	Prioritet	2003.06.23, US, 601946
(41)	Alm.tilgj	2004.12.27			
(45)	Meddelt	→2015.07.13			
(73)	Innehaver	Control Flow Inc, 9201 Fairbanks North Houston Road, US-TX77064 HOUSTON, USA			
(72)	Oppfinner	James M Adams, 12418 Winding Lane, US-TX77429 CYPRESS, USA Jason P Curtiss III, 12519 Brants Way Court, US-TX77065 HOUSTON, USA			
(74)	Fullmektig	Tandbergs Patentkontor AS, Postboks 1570 Vikta, 0118 OSLO, Norge			

(54)	Benevnelse	Strupe- og drepeledning og koplingsystem for en utblåsingssikring.			
(56)	Anførte publikasjoner	US 6089321 A US 2003024705 A1 US 2003/136927 A1			
(57)	Sammendrag				

Oppfinnelsen vedrører trykkledninger for anvendelse sammen med utstyr tilknyttet bore- og produksjonsstigerør, særlig stigerør som har låseblokkopplinger til utstyret og med strupe- og drepeledninger for anvendelse med utblåsingssikringer av forskjellige størrelser (UBIS-stakker).

Trykkledningssystemene og drepe- og strupeledningssystemene ifølge oppfinnelsen omfatter en låseblokkoppling for hurtig og enkel fjerning og installasjon av trykkledningene til stigerørsutstyret og strupe- og drepeledningene til UBIS-stakkene. Dessuten kan strupe- og drepeledningene omfatte et koplingsystem som har en UBIS koplingsanordning, eller en plateenhet for å muliggjøre anvendelse av ett sett strupe- og drepeledninger i forbindelse med en første strupe- og drepeledningskoplingsanordning. Hver strupe- og drepeledning eller -slange, omfatter en andre strupe- eller drepeledningskoplings-anordning, fortrinnsvis som del av en ledning, for løsgjørbar festing til den første strupe- eller drepeledningskoplingsanordning. Ved å installere en plateenhet for UBIS-stakker av forskjellig størrelse kan det derfor ett sett strupe- eller drepeledninger sammen med UBIS-stakker av flere forskjellige størrelser. Fremgangsmåter for utskifting UBIS-stakker og installering og fjerning av strupe- og drepeledninger beskrives.

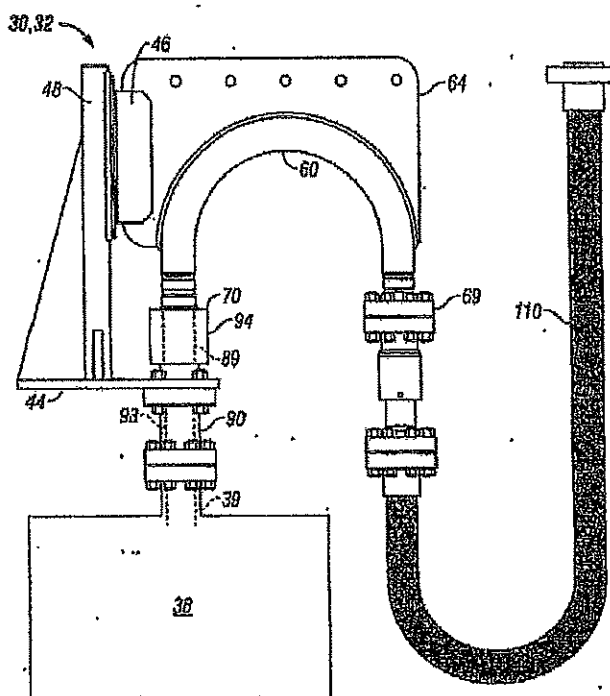



(12) PATENT

(19) NO

(11) 330579

(13) B1

NORGE

(51) Int Cl.
E21B 19/00 (2006.01)

Patentstyret

✓Co-Linear Tensioner and Methods for Assembling Production and Drilling Risers using same

(21)	Søknadsnr	20025468	(86)	Int.inng.dag og søknadsnr	
(22)	Inng.dag	→ 2002.11.15	(85)	Videreføringdag	
(24)	Løpedag	2002.11.15	(30)	Prioritet	2001.11.30, US, 000393
(41)	Alm.tilgj	2003.06.02			
(45)	Meddelt	2011.05.16			
(73)	Innehaver	Control Flow Inc, 9201 Fairbanks North Houston Road, US-TX77064 HOUSTON, USA			
(72)	Oppfinner	Graeme E Reynolds, 2053 Western Village, Houston, TX 77043, USA Timothy I Mourmian, 4237 Olive Avenue, Long Beach, CA 90807, USA			
(74)	Fullmektig	Acapo AS, Postboks 1880 Nordnes, 5817 BERGEN, Norge			

(54)	Benevnelse	Anordning ved koblingsorgan for stigerørssystemer
(56)	Anførte publikasjoner	GB 2358032 A, US 4934870 A, US 20010041096 A1
(57)	Sammendrag	

Foreliggende oppfinnelse vedrører en strekkmodul for å skaffe en rørledning, for eksempel bore- og produksjons-stigerør, fra et drivende fartøy på vannoverflaten til sjøen til utblåsnings sikringen, produksjonstre, eller en annen anordning som er koblet til brønnhodet på sjøbunnen. Strekkmodulen kompenserer for fartøysbevegelse forårsaket av bølgenes virkning, og hiv, og opprettholder en variabel strekk på stigerørsstrengen, og reduserer dermed potensialet for kompresjon og således knekking eller sammenbrudd av stigerørsstrengen. Strekkmodulen ifølge foreliggende oppfinnelse omfatter fortrinnsvis minst én røropphengsforing som omfatter minst en opphengsring, minst én øvre fleksibel dreieskjøtsammenstilling, minst én manifold med radiale åpninger, og minst én strekksylinder, kolinear kombinert i en enhet. Fremgangsmåter for å sammenstille stigerør omfattes også.

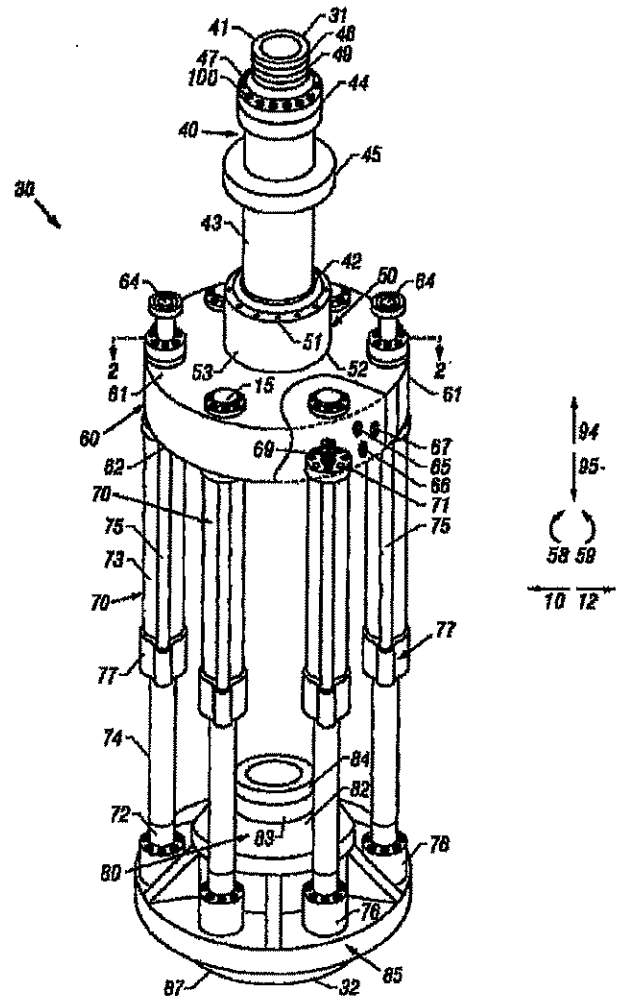



(19)

Europäisches Patentamt
European Patent Office
Office européen des brevets



(11)

EP 1 316 671 B1

(12)

EUROPEAN PATENT SPECIFICATION

(45) Date of publication and mention
of the grant of the patent:
01.06.2005 Bulletin 2005/22

(51) Int Cl.7: **E21B 19/00**

(21) Application number: **02258242.3**

(22) Date of filing: **29.11.2002**

(54) **Co-linear tensioner and methods for assembling production and drilling risers using same**

Kolineare Spannvorrichtung und Verfahren zur Montage von Bohrloch- und Produktionssteigrohren unter Verwendung desselben

Dispositif tendeur co-linéaire et méthode d'assemblage de colonnes montantes de forage et de production utilisant ce dispositif

(84) Designated Contracting States:
**AT BE BG CH CY CZ DE DK EE ES FI FR GB GR
IE IT LI LU MC NL PT SE SK TR**

(30) Priority: **30.11.2001 US 393**

(43) Date of publication of application:
04.06.2003 Bulletin 2003/23

(73) Proprietor: **Control Flow Inc.
Houston, TX 77064 (US)**

(72) Inventors:
• **Reynolds, Graeme E.
Houston, Texas 77043 (US)**

• **Mournian, Timothy I.
Long Beach, California 90807 (US)**

(74) Representative: **Newstead, Michael John et al
Page Hargrave
Southgate
Whitefriars
Lewins Mead
Bristol BS1 2NT (GB)**

(56) References cited:
**EP-A- 0 390 728 GB-A- 2 358 032
US-A1- 2001 041 096**

P 1 316 671 B1

Note: Within nine months from the publication of the mention of the grant of the European patent, any person may give notice to the European Patent Office of opposition to the European patent granted. Notice of opposition shall be filed in a written reasoned statement. It shall not be deemed to have been filed until the opposition fee has been paid. (Art. 99(1) European Patent Convention)



US006554072B1

(12) **United States Patent**
Mournian et al.

(10) Patent No.: **US 6,554,072 B1**
(45) Date of Patent: ***Apr. 29, 2003** ✓

(54) **CO-LINEAR TENSIONER AND METHODS FOR ASSEMBLING PRODUCTION AND DRILLING RISERS USING SAME**

(75) Inventors: **Timothy I. Mournian, Long Beach, CA (US); Graeme E. Reynolds, Houston, TX (US)**

(73) Assignee: **Control Flow Inc., Houston, TX (US)**

(*) Notice: Subject to any disclaimer, the term of this patent is extended or adjusted under 35 U.S.C. 154(b) by 0 days.

This patent is subject to a terminal disclaimer.

(21) Appl. No.: **10/000,393**

(22) Filed: **Nov. 30, 2001**

Related U.S. Application Data

(63) Continuation-in-part of application No. 09/881,139, filed on Jun. 14, 2001.

(60) Provisional application No. 60/211,652, filed on Jun. 15, 2000.

(51) Int. Cl.⁷ **E21B 29/12; E21B 41/04**

(52) U.S. Cl. **166/355; 166/346; 166/367; 405/224.2; 405/224.4**

(58) Field of Search **166/350, 359, 166/367, 355, 346; 405/224.4, 224.2**

(56) **References Cited**

U.S. PATENT DOCUMENTS

3,280,908 A	*	10/1966	Todd	166/340
3,313,345 A	*	4/1967	Fischer	166/355
3,643,751 A		2/1972	Crickmer	
3,955,621 A	*	5/1976	Webb	166/355
4,068,868 A		1/1978	Ohr	
4,215,950 A	*	8/1980	Stevenson	114/264

4,317,586 A	*	3/1982	Campbell	285/145.4
4,367,981 A	*	1/1983	Shapiro	166/355
4,379,657 A	*	4/1983	Widiner et al.	405/168.4
4,615,542 A		10/1986	Ideno et al.	
4,712,620 A		12/1987	Lim et al.	
4,787,778 A	*	11/1988	Myers et al.	166/367
4,808,035 A	*	2/1989	Stanton et al.	166/355
4,883,387 A	*	11/1989	Myers et al.	166/367
5,727,630 A		3/1998	Brammer	
5,846,028 A		12/1998	Thory	
5,951,061 A		9/1999	Arlt, III et al.	
6,419,277 B1	*	7/2002	Reynolds	166/367

FOREIGN PATENT DOCUMENTS

GB	2141470 A	12/1984
WO	WO 97/43516	11/1997
WO	WO 00/24998	5/2000

* cited by examiner

Primary Examiner—Robert E. Pezzuto

Assistant Examiner—Thomas A. Beach

(74) *Attorney, Agent, or Firm*—Anthony F. Matheny; Andrews & Kurth L.L.P.

(57) **ABSTRACT**

A tensioner for providing a conduit, e.g., drilling and production riser strings, from a floating vessel at the surface of the ocean to the blowout preventer stack, production tree, or other assembly which is connected to the wellhead at the sea floor. The tensioner compensates for vessel motion induced by wave action and heave and maintains a variable tension to the riser string alleviating the potential for compression and thus buckling or failure of the riser string. The tensioner of the present invention preferably includes at least one mandrel having at least one hang-off donut; at least one upper flexjoint swivel assembly, at least one radially ported manifold, and at least one tensioning cylinder co-linearly combined in a single unit. Methods for assembling risers are also disclosed.

47 Claims, 7 Drawing Sheets

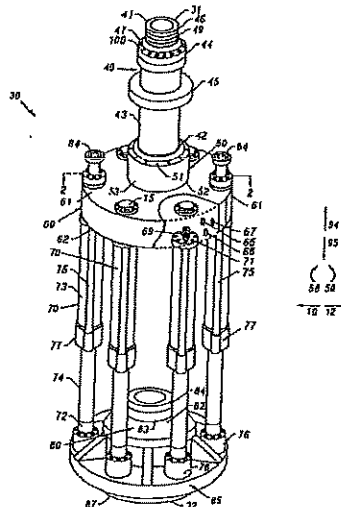

**THE REGISTRY OF PATENTS
SINGAPORE**

THE PATENTS ACT
(CHAPTER 221)

CERTIFICATE OF GRANT OF PATENT

In accordance with section 35 of the Patents Act, it is hereby certified that a patent having the P-No. 98499 has been granted in respect of an invention having the following particulars:

Title : CO-LINEAR TENSIONER AND METHODS FOR
ASSEMBLING PRODUCTION AND DRILLING
RISERS USING SAME

Application Number : 200207166-0

Date of Filing : 27 November 2002

Priority Data : 30 November 2001 - PATENT APPLICATION NO.
10/000,393 (UNITED STATES OF AMERICA)

Name of Inventor(s) : GRAEME E. REYNOLDS;
TIMOTHY I. MOURNIAN

Name(s)
and Address(es) of
Proprietor(s) of Patent : CONTROL FLOW, INC.
9201 FAIRBANKS NORTH HOUSTON ROAD
HOUSTON, TEXAS 77064
UNITED STATES OF AMERICA

Date of Grant : 30 December 2005

Dated this 30th day of December 2005.



Liew Woon Yin (Ms)
Registrar of Patents.
Singapore.

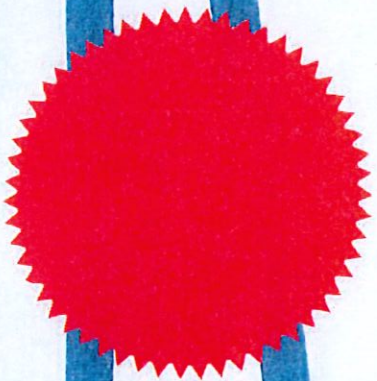



REPÚBLICA FEDERATIVA DO BRASIL
MINISTÉRIO DO DESENVOLVIMENTO, INDÚSTRIA E COMÉRCIO EXTERIOR
INSTITUTO NACIONAL DA PROPRIEDADE INDUSTRIAL

CARTA PATENTE Nº PI 0205824-3

O INSTITUTO NACIONAL DA PROPRIEDADE INDUSTRIAL concede a presente PATENTE DE INVENÇÃO, que outorga ao seu titular a propriedade da invenção caracterizada neste título, em todo o território nacional, garantindo os direitos dela decorrentes, previstos na legislação em vigor.

✓ **Co-Linear Tensioner and Methods for Assembling Production & Drilling Risers Using Same**

(21) Número do Depósito: PI 0205824-3

(22) Data do Depósito: 27/11/2002

(43) Data da Publicação do Pedido: 28/10/2003

(51) Classificação Internacional: E21B 17/01

(30) Prioridade Unionista: 30/11/2001 US 10/000,393

(54) Título: TENSOR CO-LINEAR E MÉTODOS PARA MONTAGEM DE COLUNAS DE TUBOS ASCENDENTES DE AÇO DE PRODUÇÃO E DE PERFURAÇÃO COM O USO DO MESMO

(73) Titular: CONTROL FLOW, INC.. Endereço: 9201 Fairbanks North Houston Road, Houston, Texas 77064, Estados Unidos (US).

(72) Inventor: TIMOTHY I. MOURNIAN; GRAEME E. REYNOLDS

Prazo de Validade: 10 (dez) anos contados a partir de 21/01/2015, observadas as condições legais.

Expedida em: 21 de Janeiro de 2015. ←

Assinado digitalmente por:

Liane Elizabeth Caldeira Lage
Diretora de Patentes Substituta

(12) **United States Patent**
Williams

(10) **Patent No.:** **US 7,337,849 B2**

(45) **Date of Patent:** **Mar. 4, 2008**

(54) **CO-LINEAR TENSIONER AND METHODS OF INSTALLING AND REMOVING SAME**

(75) Inventor: **Richard D. Williams, Sugar Land, TX (US)**

(73) Assignee: **Control Flow Inc., Houston, TX (US)**

(*) Notice: Subject to any disclaimer, the term of this patent is extended or adjusted under 35 U.S.C. 154(b) by 0 days.

(21) Appl. No.: **11/487,270**

(22) Filed: **Jul. 14, 2006**

(65) **Prior Publication Data**

US 2006/0254776 A1 Nov. 16, 2006

Related U.S. Application Data

(63) Continuation of application No. 11/060,660, filed on Feb. 17, 2005.

(51) **Int. Cl.**

E21B 29/12 (2006.01)

(52) **U.S. Cl.** **166/355; 166/359; 166/367**

(58) **Field of Classification Search** **166/355,**

166/346, 367, 359; 405/224.2, 224.4
See application file for complete search history.

(56) **References Cited**

U.S. PATENT DOCUMENTS

4,808,035 A * 2/1989 Stanton et al. 405/224.4
5,658,095 A * 8/1997 Arlt et al. 405/195.1

5,846,028 A * 12/1998 Thory 405/195.1
6,554,072 B1 * 4/2003 Mouraian et al. 166/355
6,585,455 B1 * 7/2003 Petersen et al. 405/224.4
2005/0074296 A1 * 4/2005 McCarty et al. 405/224.4
2006/0016605 A1 * 1/2006 Coles 166/355
2006/0151176 A1 * 7/2006 Moe 166/355

* cited by examiner

Primary Examiner—Thomas A Beach

(74) *Attorney, Agent, or Firm*—Greenberg Traurig LLP; Anthony F. Matheny

(57) **ABSTRACT**

The invention is directed to a tensioner for providing linear and angular movement of a drilling or production facility relative to a conduit or riser secured to the tensioner and to the wellhead in offshore operations. The tensioner compensates for vessel motion induced by wave action and heave and maintains a variable tension to the riser string alleviating the potential for compression and thus buckling or failure of the riser string. The tensioner of the present invention preferably includes at least one top load plate that facilitates easy and quick installation and removal of the tensioner from the rig floor of the vessel or platform. The tensioner also facilitates the placement of at least one piece of equipment disposed within the area formed by the tensioning cylinders. The tensioner may also include one or more pieces of equipment, e.g., a rotary table, integrally formed with the tensioner to further increase the ease and speed of installation and removal of the tensioner from the rig floor. Methods for installing and removing tensioners from the rig floor are also disclosed.

25 Claims, 6 Drawing Sheets

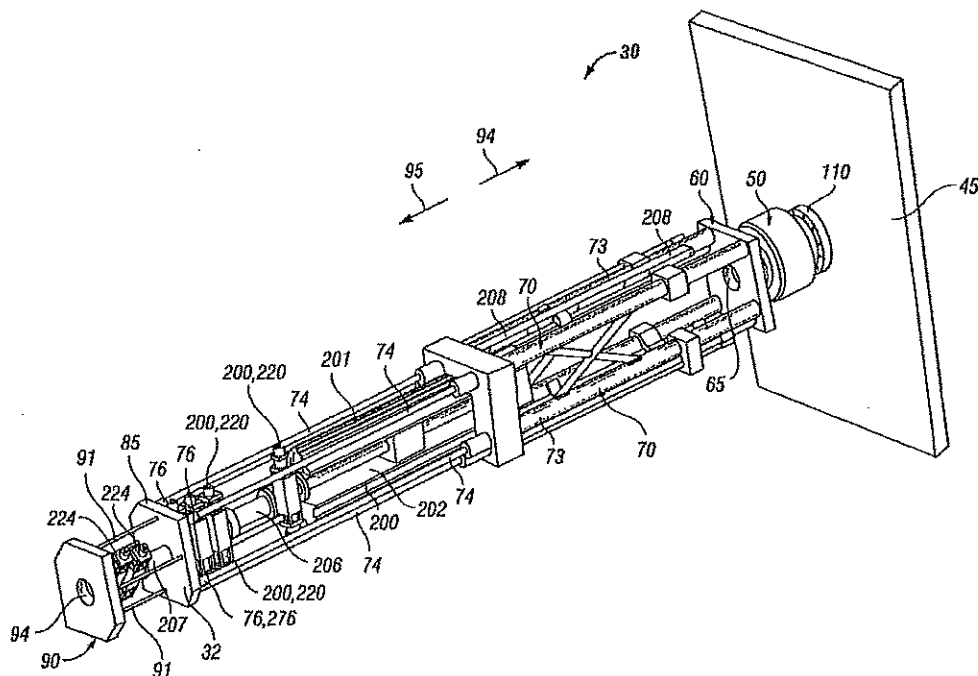

United States Patent [19]

Jordan

[11] Patent Number: 4,540,159

[45] Date of Patent: Sep. 10, 1985

[54] HYDROPNEUMATIC CABLE TENSIONER

[75] Inventor: Larry B. Jordan, Houston, Tex.

[73] Assignee: Retesco, Inc., Houston, Tex.

[21] Appl. No.: 516,102

[22] Filed: Jul. 22, 1983

[51] Int. Cl.³ B25B 25/00; B66D 1/50

[52] U.S. Cl. 254/228; 254/277;

254/386; 254/392

[58] Field of Search 254/228, 272, 277, 386,

254/392; 92/143

[36]

References Cited

U.S. PATENT DOCUMENTS

2,588,037 3/1952 Orton, Sr. 242/47.5

3,120,157 2/1964 Mello 91/408

3,314,697 4/1967 Frud'homme et al. 254/189

3,403,728 10/1968 Richardson et al. 254/277 X

3,912,227 10/1975 Meeker et al. 254/277 X

4,145,959 3/1979 Burden et al. 92/143 X

FOREIGN PATENT DOCUMENTS

12110 of 1884 United Kingdom .

919768 2/1963 United Kingdom 254/228

Primary Examiner—Stuart S. Levy

Assistant Examiner—Joseph J. Hall, III

Attorney, Agent, or Firm—Baker & Kirk

[57]

ABSTRACT

A hydropneumatic cable tensioner is comprised of an enclosed cylinder featuring a plurality of annular chambers. A fixed cable sheave is mounted to one end of the cylinder. A movable cable sheave is mounted to a piston rod connected to a piston which reciprocates in the innermost or piston bore chamber of the cylinder. Regulated compressed gas is connected to the outer chamber of the cylinder thereby exerting high pressure forces on oil found in the middle or high pressure oil chamber of the cylinder. Pressurized oil forces a piston to move outwardly thereby increasing the distance between the two sheaves and tensioning a cable. Restriction means within the piston bore chamber regulate movement of the piston and prevent uncontrolled acceleration should a cable failure occur.

8 Claims, 5 Drawing Figures

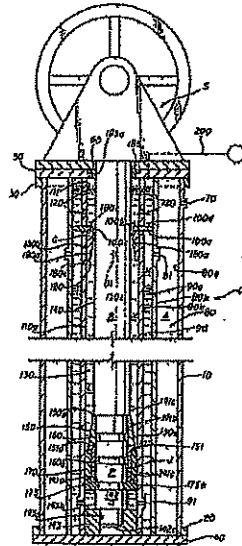



REPUBLIC OF SINGAPORE
THE PATENT ACT (CHAPTER 221)
CERTIFICATE ISSUED UNDER SECTION 35

I HEREBY CERTIFY that under the provisions of the Patent Act, a patent has been granted in respect of an invention having the following particulars:

TITLE : LINEAR PIPE RECOVERY/LAY TENSIONERS AND METHODS OF USING SAME

APPLICATION NUMBER : 2013004718

PATENT NUMBER : 192370

DATE OF FILING : 21 JANUARY 2013

PRIORITY DATA : 24 JANUARY 2012 - PATENT APPLICATION NO. 13/357,007 (UNITED STATES OF AMERICA)

NAME OF INVENTOR(S) : PATRICK K. ALLOWAY;
KEVIN L. PRESTON;
LOREN D. SKILES

NAME(S) AND ADDRESS(ES) OF PROPRIETOR(S) OF PATENT : CONTROL FLOW INC.
9201 FAIRBANKS NORTH HOUSTON ROAD,
HOUSTON, TEXAS 77064
UNITED STATES OF AMERICA

DATE OF GRANT : 16 February 2017

DATED THIS 16th DAY OF FEBRUARY 2017



Daren Tang Heng Shim
Registrar of Patents
Singapore



US008821069B2

(12) **United States Patent**
Alloway et al.

(10) **Patent No.:** **US 8,821,069 B2**
(45) **Date of Patent:** **Sep. 2, 2014**

(54) **LINEAR PIPE RECOVERY/LAY TENSIONERS AND METHODS OF USING SAME**

(75) Inventors: **Patrick K. Alloway**, Magnolia, TX (US); **Kevin L. Preston**, Houston, TX (US); **Loren D. Skiles**, Tomball, TX (US)

(73) Assignee: **Control Flow, Inc.**, Houston, TX (US)

(*) Notice: Subject to any disclaimer, the term of this patent is extended or adjusted under 35 U.S.C. 154(b) by 116 days.

(21) Appl. No.: **13/357,007**

(22) Filed: **Jan. 24, 2012**

(65) **Prior Publication Data**

US 2013/0189035 A1 Jul. 25, 2013

(51) **Int. Cl.**
F16L 1/23 (2006.01)
E21B 19/22 (2006.01)

(52) **U.S. Cl.**
USPC **405/168.4; 226/173**

(58) **Field of Classification Search**
USPC **405/166, 168.1, 168.4, 184; 226/172, 226/173, 188; 166/77.3; 74/162**
See application file for complete search history.

(56) **References Cited**

U.S. PATENT DOCUMENTS

3,754,474 A *	8/1973	Palynchuk	74/162
3,982,402 A	9/1976	Lang et al.	
4,230,421 A	10/1980	Springett et al.	
4,269,540 A	5/1981	Uyeda et al.	
4,297,054 A	10/1981	Yenzler et al.	
RE30,846 E	1/1982	Lang et al.	
4,340,322 A	7/1982	Springett et al.	
4,345,855 A	8/1982	Uyeda et al.	

4,469,267 A *	9/1984	Franchuk et al.	226/172
4,687,376 A	8/1987	Recalde	
4,721,411 A	1/1988	Recalde	
4,723,874 A	2/1988	Recalde	
4,765,776 A	8/1988	Howson	
4,789,108 A	12/1988	Recalde	
4,820,082 A	4/1989	Recalde	
4,917,540 A	4/1990	Recalde	
4,961,671 A	10/1990	Recalde	
4,984,934 A	1/1991	Recalde	
5,451,084 A *	9/1995	Jansch	166/77.53
5,527,134 A	6/1996	Recalde	
5,533,834 A	7/1996	Recalde	
5,692,859 A *	12/1997	Dickson et al.	405/168.4
6,056,478 A	5/2000	Martin et al.	
6,328,502 B1	12/2001	Hickey et al.	

(Continued)

OTHER PUBLICATIONS

Sparrows Baricon, Cable/Pipe Tensioner, Model BS199-15.0 Te., Sparrows Baricon, Aberdeen, UK (undated).

Primary Examiner — John Kreck
Assistant Examiner — Kyle Armstrong

(57) **ABSTRACT**

Linear pipe recovery/lay tensioners can include one or more pivot assemblies for rotatably moving an upper track away from a lower track to facilitate placement of a pipe segment between the two tracks. In addition, or alternatively, the tensioners can include one or more hydraulic cylinders that provide flexible suspension to the upper and lower tracks so the tracks can move and rotate as necessary due to differing pipe segment shapes. In addition, or alternatively, the upper and lower tracks include one or more gripping pad having one or more gripping member that is sheathed by a compliant member until such time as the pipe segment compresses the compliant member causing the gripping member(s) to protrude from the compliant member and bite into the pipe segment. Rotation of the tracks is controlled by a hydraulic pump capable of rotating the tracks at the same rate or at different rates.

14 Claims, 6 Drawing Sheets

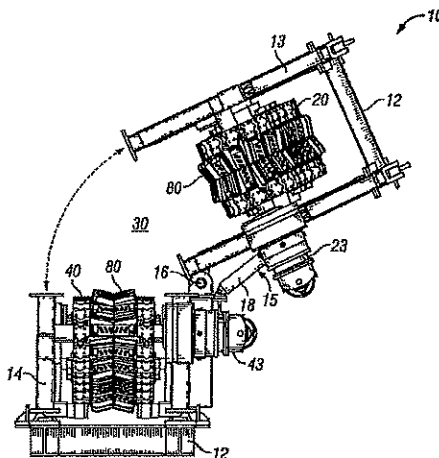
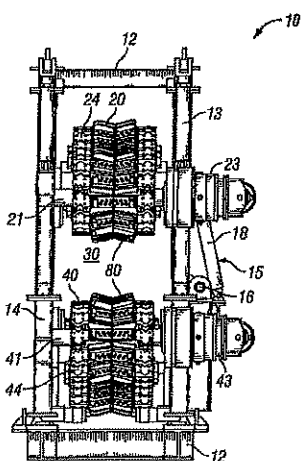



US009671044B2

(12) **United States Patent**
Alloway et al.

(10) **Patent No.:** US 9,671,044 B2
(45) **Date of Patent:** *Jun. 6, 2017

(54) **LINEAR PIPE RECOVERY/LAY TENSIONERS AND METHOD OF USING SAME**

(71) Applicant: **Control Flow, Inc.**, Houston, TX (US)

(72) Inventors: **Patrick K. Alloway**, Waller, TX (US);
Kevin L. Preston, Tomball, TX (US);
Loren D. Skiles, Tomball, TX (US)

(73) Assignee: **Control Flow, Inc.**, Houston, TX (US)

(*) Notice: Subject to any disclaimer, the term of this patent is extended or adjusted under 35 U.S.C. 154(b) by 29 days.

This patent is subject to a terminal disclaimer.

(21) Appl. No.: 14/475,334

(22) Filed: Sep. 2, 2014

(65) **Prior Publication Data**

US 2014/0369763 A1 Dec. 18, 2014

Related U.S. Application Data

(63) Continuation-in-part of application No. 13/357,007, filed on Jan. 24, 2012, now Pat. No. 8,821,069.

(51) **Int. Cl.**
F16L 1/23 (2006.01)
E21B 19/22 (2006.01)
B65H 51/14 (2006.01)

(52) **U.S. Cl.**
CPC *F16L 1/23* (2013.01); *B65H 51/14* (2013.01); *E21B 19/22* (2013.01)

(58) **Field of Classification Search**
USPC 405/166, 168.1, 168.4, 184; 226/172, 226/173, 188; 166/77.3; 74/162
See application file for complete search history.

(56) **References Cited**

U.S. PATENT DOCUMENTS

3,754,474 A	8/1973	Palynchuk
4,469,267 A	9/1984	Franchuk et al.
5,451,084 A	9/1995	Jansch
5,692,859 A	12/1997	Dickson et al.
2003/0219313 A1	11/2003	Giovannini et al.
2008/0017388 A1	1/2008	Kulhanek et al.
2010/0034592 A1	2/2010	Roodenburg et al.

Primary Examiner — Kyle Armstrong

(57) **ABSTRACT**

Linear pipe recovery/lay tensioners can include one or more pivot assemblies for rotatably moving an upper track away from a lower track to facilitate placement of a pipe segment between the two tracks. In addition, or alternatively, the tensioners can include one or more hydraulic cylinders that provide flexible suspension to the upper and lower tracks so the tracks can move and rotate as necessary due to differing pipe segment shapes. In addition, or alternatively, the upper and lower tracks include one or more gripping pads having one or more gripping members that can be sheathed by a compliant member until such time as the pipe segment compresses the compliant member causing the gripping member(s) to protrude from the compliant member and engage the pipe segment. Rotation of the tracks is controlled by a hydraulic pump capable of rotating the tracks at the same rate or at different rates.

16 Claims, 8 Drawing Sheets

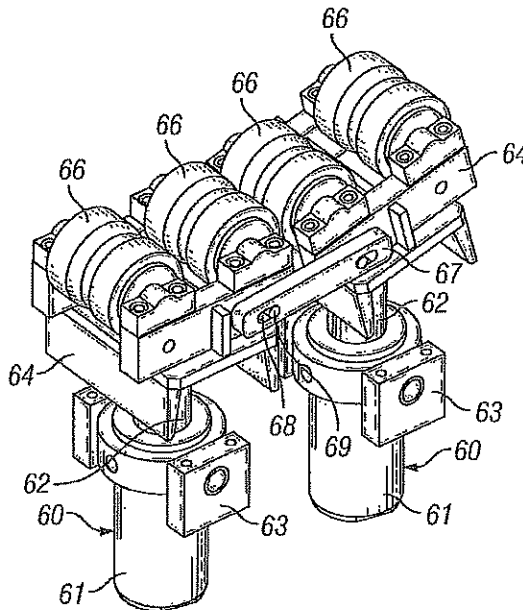



(11) **EP 2 620 682 B1**

(12) **EUROPEAN PATENT SPECIFICATION**

(45) Date of publication and mention
of the grant of the patent:

→ 18.10.2019 Bulletin 2019/42

(51) Int Cl.:

F16L 1/23 (2006.01)

B65H 51/14 (2006.01)

(21) Application number: 13275014.2

(22) Date of filing: 18.01.2013

→ (54) **PIPE TENSIONER**

ROHRSPANNGERÄT

TENDEUR DE TUYAU

(84) Designated Contracting States:
AL AT BE BG CH CY CZ DE DK EE ES FI FR GB
GR HR HU IE IS IT LI LT LU LV MC MK MT NL NO
PL PT RO RS SE SI SK SM TR

(30) Priority: 24.01.2012 US 201213357007

(43) Date of publication of application:
31.07.2013 Bulletin 2013/31

(73) Proprietor: Control Flow Inc.
Houston, TX 77064 (US)

(72) Inventors:
• Alloway, Patrick K.
Magnolia, Texas 77355 (US)
• Preston, Kevin L.
Houston, Texas 77068 (US)

• Skiles, Loren D.
Tomball, Texas 77377 (US)

(74) Representative: Barker Brettell LLP
100 Hagley Road
Edgbaston
Birmingham B16 8QQ (GB)

(56) References cited:
US-A- 3 559 905 US-A- 3 739 971
US-A- 3 754 474 US-A1- 2010 034 592

• TECHMDL: "50 Te, 4 Track Pipe or Cable lay
Tensioner, made in UK", youtube, 1 April 2011
(2011-04-01), page 1 pp., XP054977340, Retrieved
from the Internet:
URL: <https://www.youtube.com/watch?v=Jlx8FLM08kY> [retrieved on 2017-05-10]

EP 2 620 682 B1

Note: Within nine months of the publication of the mention of the grant of the European patent in the European Patent Bulletin, any person may give notice to the European Patent Office of opposition to that patent, in accordance with the Implementing Regulations. Notice of opposition shall not be deemed to have been filed until the opposition fee has been paid. (Art. 99(1) European Patent Convention).



IPI
INSTITUTO
NACIONAL DA
PROPRIEDADE
INDUSTRIAL
Assinado
Digitalmente

REPÚBLICA FEDERATIVA DO BRASIL
MINISTÉRIO DA ECONOMIA
INSTITUTO NACIONAL DA PROPRIEDADE INDUSTRIAL

CARTA PATENTE Nº BR 102013001466-4

O INSTITUTO NACIONAL DA PROPRIEDADE INDUSTRIAL concede a presente PATENTE DE INVENÇÃO, que outorga ao seu titular a propriedade da invenção caracterizada neste título, em todo o território nacional, garantindo os direitos dela decorrentes, previstos na legislação em vigor.

(21) Número do Depósito: BR 102013001466-4

(22) Data do Depósito: 21/01/2013

(43) Data da Publicação Nacional: 02/12/2014

(51) Classificação Internacional: F16L 1/23.

(30) Prioridade Unionista: US 13/357,007 de 24/01/2012.

(54) Título: TENSORES DE RECUPERAÇÃO/INSTALAÇÃO DE TUBOS LINEARES E MÉTODOS PARA O USO DOS MÊSMOS

(73) Titular: CONTROL FLOW INC, Pessoa Jurídica. Endereço: 9201 Fairbanks North Houston Road, Houston, Texas 77064, ESTADOS UNIDOS DA AMÉRICA(US)

(72) Inventor: PATRICK K. ALLOWAY; KEVIN L. PRESTON; LOREN D. SKILES.

Prazo de Validade: 20 (vinte) anos contados a partir de 21/01/2013, observadas as condições legais

Expedida em: 08/12/2020 ←

Assinado digitalmente por:

Liane Elizabeth Caldeira Lage

Diretora de Patentes, Programas de Computador e Topografias de Circuitos Integrados



US011035509B2

(12) **United States Patent**
Irvine et al.

(10) **Patent No.:** US 11,035,509 B2
(45) **Date of Patent:** Jun. 15, 2021

(54) **METAL-TO-METAL WELL EQUIPMENT SEAL**

(71) Applicants: **Jock W. Irvine**, Houston, TX (US);
Thomas M. Lambert, Houston, TX (US)

(72) Inventors: **Jock W. Irvine**, Houston, TX (US);
Thomas M. Lambert, Houston, TX (US)

(73) Assignee: **CONTROL FLOW, INC.**, Houston, TX (US)

(*) Notice: Subject to any disclaimer, the term of this patent is extended or adjusted under 35 U.S.C. 154(b) by 0 days.

(21) Appl. No.: 15/600,440

(22) Filed: May 19, 2017

(65) **Prior Publication Data**

US 2017/0336003 A1 Nov. 23, 2017

Related U.S. Application Data

(60) Provisional application No. 62/338,905, filed on May 19, 2016.

(51) **Int. Cl.**
F16L 23/20 (2006.01)
G01M 3/02 (2006.01)
F16L 23/16 (2006.01)
F16J 15/08 (2006.01)
E21B 33/03 (2006.01)

(52) **U.S. Cl.**
CPC *F16L 23/20* (2013.01); *E21B 33/03* (2013.01); *F16J 15/08* (2013.01); *F16L 23/167* (2013.01); *G01M 3/022* (2013.01); *F16L 2201/30* (2013.01)

(58) **Field of Classification Search**
CPC F16J 15/02; F16J 15/062; F16J 15/064; F16J 15/08; F16J 15/0881; F16J 15/0887; F16J 15/0893; F16L 23/20; F16L 15/008; F16L 15/053; F16L 19/0218
USPC 285/368, 351, 334.2, 371, 353, 354
See application file for complete search history.

(56) **References Cited**

U.S. PATENT DOCUMENTS

1,858,136 A * 5/1932 Brenner F16L 19/04
285/332.4
1,873,855 A * 8/1932 Wilson F16L 23/20
277/614

(Continued)

FOREIGN PATENT DOCUMENTS

CH 499052 A 12/1970
BP 2828560 B1 3/2017
BP 2619496 B1 11/2019

Primary Examiner — Kristina R. Fulton

Assistant Examiner — L. Susmitha Koneru

(74) *Attorney, Agent, or Firm* — Matthews, Lawson, McCutcheon & Joseph, PLLC

(57) **ABSTRACT**

A metal-to-metal sealing system is described for forming a pressure-activated connection between two pieces of equipment under HPHT (high pressure high temperature) conditions which will degrade elastomers. The roughly cylindrical seal comprises four sealing surfaces, two sealing surfaces formed by the circular longitudinal edge, and two sealing surfaces formed by either side of a bulge located halfway along the outer diameter. These surfaces correspond with sealing surfaces on the pieces of equipment to be joined. These pieces of equipment also utilize testing ports in fluid communication with the seal in order to ensure a secure connection.

7 Claims, 7 Drawing Sheets

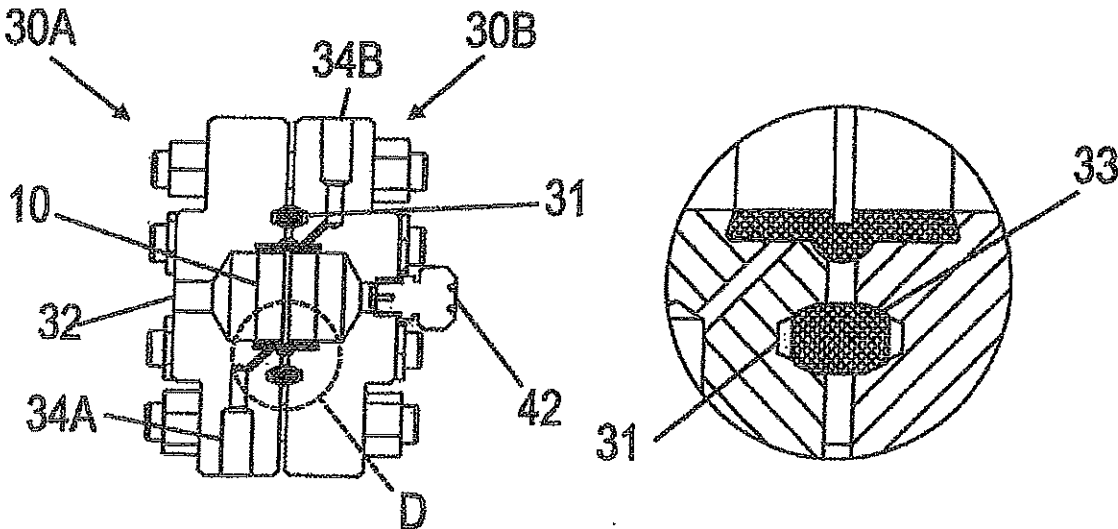

TÍTULO DE PATENTE No. 401089

Titular(es): CONTROL FLOW, INC.
Domicilio: Fairbanks N Houston Rd 9201, Houston, Texas, 77064-6206, E.U.A.
Denominación: OBTURADOR DE EQUIPO DE POZO DE METAL A METAL.
Clasificación: CIP: E21B33/00; E21B33/03; E21B33/038
CPC: E21B33/03; F16L23/20; F16L23/167; G01M3/022; F16L2201/30
Inventor(es): JOCK, W. IRVINE; THOMAS, M. LAMBERT

SOLICITUD

Número:
MX/a/2018/013982

Fecha de Presentación Internacional:
19 de Mayo de 2017

PRIORIDAD

País:

US

US

Fecha:

19 de mayo de 2016

19 de mayo de 2017

Número:

62/338,905

15/600,440

Vigencia: Veinte años

Fecha de Vencimiento: 19 de mayo de 2037

Fecha de Expedición: 21 de marzo de 2023

La patente de referencia se otorga con fundamento en los artículos 1º, 2º fracción V, 6º fracción III, y 59 de la Ley de la Propiedad Industrial.

De conformidad con el artículo 23 de la Ley de la Propiedad Industrial, la presente patente tiene una vigencia de veinte años improrrogables, contada a partir de la fecha de presentación de la solicitud internacional y estará sujeta al pago de la tarifa para mantener vigentes los derechos.

Quien suscribe el presente título lo hace con fundamento en lo dispuesto por los artículos 5º fracción I, 9, 10 y 119 de la Ley Federal de Protección a la Propiedad Industrial; artículos 1º, 3º fracción V, inciso a), 4º y 12º fracciones I y III del Reglamento del Instituto Mexicano de la Propiedad Industrial; artículos 1º, 3º, 4º, 5º fracción V, inciso a), 16 fracciones I y III y 30 del Estatuto Orgánico del Instituto Mexicano de la Propiedad Industrial; 1º, 3º y 5º fracción I Acuerdo Delegatorio de Facultades del Instituto Mexicano de la Propiedad Industrial.

El presente documento electrónico ha sido firmado mediante el uso de la firma electrónica avanzada por el servidor público competente, amparada por un certificado digital vigente a la fecha de su elaboración, y es válido de conformidad con lo dispuesto en los artículos 7 y 9 fracción I de la Ley de Firma Electrónica Avanzada y artículo 12 de su Reglamento. Su integridad y autoría, se podrá comprobar en www.qob.mx/impi.

Asimismo, se emitió conforme lo previsto por los artículos 1º fracción III; 2º fracción VI; 37, 38 y 39 del Acuerdo por el que se establecen lineamientos en materia de Servicios Electrónicos del Instituto Mexicano de la Propiedad Industrial.

SUBDIRECTORA DIVISIONAL DE EXAMEN DE FONDO DE PATENTES ÁREAS MECÁNICA, ELÉCTRICA Y DE DISEÑOS INDUSTRIALES Y MODELOS DE UTILIDAD

MARINA OLIMPIA CASTRO ALVEAR



Cadena Original:

MARINA OLIMPIA CASTRO ALVEAR|00001000000510738631|SERVICIO DE ADMINISTRACION
TRIBUTARIA|1987||MX/2023/30218|MX/a/2018/013982|Título de patente PCT|1980|SRH|Pág(s)
1|+UwOfdIA5aZ6LHl1tJ+FAQx9jfi=

Sello Digital:

cDGkPC1C2B5bBULprpJnTYgjlVkn3HFW1SpVP5fDeLJyaSdYdJz56sonjEoPJCh52LVxKfsJE/7Wax2gXznID6ZJ
vtdpbOf1q3ycxysttUv6FfPAzgzGv8U7wf2Wo1KgZ078WGPkvh4DbQ4BuE4TF+huZE1408TNYxfMyCmtOEUXFP7h+
sul5Sn+8aCRVSA7r2h4jz5aJsZz09wz3X5ushedvQ7KeLXPfWduCeEFzSk9CLOymQOrpOD/pU GgTgl/T9Tgs3McN16
qNmUy+meO9vK7XWkAZE9g4wufUHbQWZlOWXmBKXLiICg6Wg92A3AMXv6pUArHyOabuYpitA==



MX/2023/30218



INPI
INSTITUTO
NACIONAL
DE PROPRIEDADE
INDUSTRIAL
Assinado
Digitalmente

REPÚBLICA FEDERATIVA DO BRASIL
MINISTÉRIO DO DESENVOLVIMENTO, INDÚSTRIA, COMÉRCIO E SERVIÇOS
INSTITUTO NACIONAL DA PROPRIEDADE INDUSTRIAL

CARTA PATENTE Nº BR 112018073573-6

O INSTITUTO NACIONAL DA PROPRIEDADE INDUSTRIAL concede a presente PATENTE DE INVENÇÃO, que outorga ao seu titular a propriedade da invenção caracterizada neste título, em todo o território nacional, garantindo os direitos dela decorrentes, previstos na legislação em vigor.

(21) Número do Depósito: BR 112018073573-6

(22) Data do Depósito: 19/05/2017

(43) Data da Publicação Nacional: 29/10/2019

(51) Classificação Internacional: E21B 33/00; E21B 33/03; E21B 33/038.

(30) Prioridade Unionista: US 62/338,905 de 19/05/2016; US 15/600,440 de 19/05/2017.

(54) Título: EQUIPAMENTO VEDADOR METAL-METAL DE POÇO

(73) Titular: CONTROL FLOW, INC., Pessoa Jurídica. Endereço: 9201 FAIRBANKS NORTH HOUSTON ROAD, HOUSTON, TEXAS 77064, ESTADOS UNIDOS DA AMÉRICA(US), Norte Americana

(72) Inventor: JOCK W. IRVINE; THOMAS M. LAMBERT.

(87) Publicação PCT: WO 2017/201474 de 23/11/2017

Prazo de Validade: 20 (vinte) anos contados a partir de 19/05/2017, observadas as condições legais

Expedida em: 16/05/2023

Assinado digitalmente por:

Alexandre Dantas Rodrigues

Diretor Substituto de Patentes, Programas de Computador e Topografias de Circuitos Integrados

15 de Novembro
REPÚBLICA FEDERATIVA DO BRASIL
de 1889



US 20090008513A1

(19) **United States**

(12) **Patent Application Publication**
Preston et al.

(10) **Pub. No.: US 2009/0008513 A1**

(43) **Pub. Date: Jan. 8, 2009**

(54) **PIPE ROLLER ASSEMBLY**

Publication Classification

(75) **Inventors:** Kevin L. Preston, Tomball, TX (US); H. Paul Reinhardt, JR., Houston, TX (US); Loren D. Skiles, Tomball, TX (US)

(51) **Int. Cl.**
F16L 3/16 (2006.01)
(52) **U.S. Cl.** 248/55; 242/397.3; 242/615.2; 248/371

Correspondence Address:
GREENBERG TRAURIG (HOU)
INTELLECTUAL PROPERTY DEPARTMENT
1000 Louisiana Street, Suite 1800
Houston, TX 77002 (US)

(57) **ABSTRACT**

Roller assemblies for transporting and laterally shifting pipe section, or joints, on oil and gas exploration and production laybarges, drilling/production vessels and platforms, and pipe spooling yards are disclosed. The roller assemblies comprise rollers that are capable of being tilted to facilitate lateral shifting of the pipe sections or joints. The roller assemblies comprise a frame, a tilting assembly, a roller frame pivotally connected to the tilting assembly and the frame, and a roller rotatably connected to the roller frame by an axle. The tilting assembly lifts one end of the roller frame to tilt the roller.

(73) **Assignee:** CONTROL FLOW INC.
(21) **Appl. No.:** 11/824,640
(22) **Filed:** Jul. 2, 2007

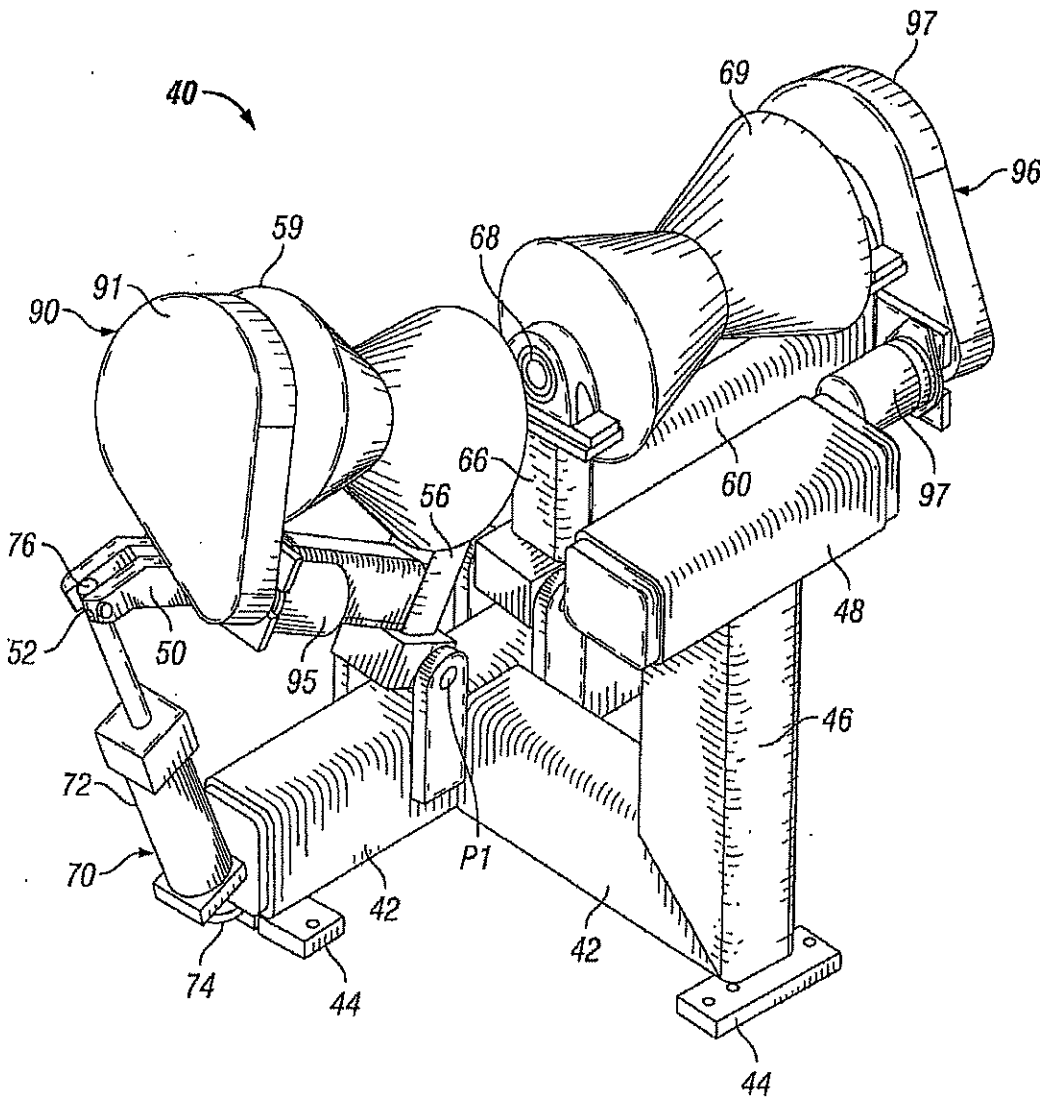



US007815032B2

(12) **United States Patent**
Preston et al.

(10) **Patent No.:** **√US 7,815,032 B2**
(45) **Date of Patent:** **Oct. 19, 2010**

(54) **PIPE ROLLER ASSEMBLY**

(75) **Inventors:** **Kevin L. Preston, Tomball, TX (US); H. Paul Reinhardt, Jr., Houston, TX (US); Loren D. Skiles, Tomball, TX (US)**

(73) **Assignee:** **Control Flow Inc., Houston, TX (US)**

(*) **Notice:** Subject to any disclaimer, the term of this patent is extended or adjusted under 35 U.S.C. 154(b) by 649 days.

3,348,678 A *	10/1967	Flowers	198/369.3
3,446,367 A *	5/1969	Anderson	198/782
4,067,450 A *	1/1978	Birdwell	414/746.7
4,593,807 A *	6/1986	Cattaneo et al.	198/463.3
5,450,943 A *	9/1995	Yew et al.	198/468.6
5,878,863 A *	3/1999	Madden et al.	198/370.04
6,149,376 A *	11/2000	Peting	414/746.3
7,341,140 B1 *	3/2008	Warkentin	198/369.3

(21) **Appl. No.:** **11/824,640**

(22) **Filed:** **Jul. 2, 2007**

(65) **Prior Publication Data**

US 2009/0008513 A1 Jan. 8, 2009

(51) **Int. Cl.**
B65G 47/46 (2006.01)

(52) **U.S. Cl.** **198/369.6; 198/369.3; 198/370.09; 198/463.2**

(58) **Field of Classification Search** **198/370.04, 198/370.09, 597, 598, 369.3, 369.4, 369.6, 198/782, 786, 463.2, 463.3; 414/22.65, 745.4, 414/746.7, 746.4**

See application file for complete search history.

(56) **References Cited**

U.S. PATENT DOCUMENTS

3,129,805 A * 4/1964 Krahn et al. 198/783

* cited by examiner

Primary Examiner—James R Bidwell

(74) *Attorney, Agent, or Firm*—Greenberg Traurig LLP; Anthony F. Matheny

(57) **ABSTRACT**

Roller assemblies for transporting and laterally shifting pipe section, or joints, on oil and gas exploration and production laybarges, drilling/production vessels and platforms, and pipe spooling yards are disclosed. The roller assemblies comprise rollers that are capable of being tilted to facilitate lateral shifting of the pipe sections or joints. The roller assemblies comprise a frame, a tilting assembly, a roller frame pivotally connected to the tilting assembly and the frame, and a roller rotatably connected to the roller frame by an axle. The tilting assembly lifts one end of the roller frame to tilt the roller.

21 Claims, 2 Drawing Sheets

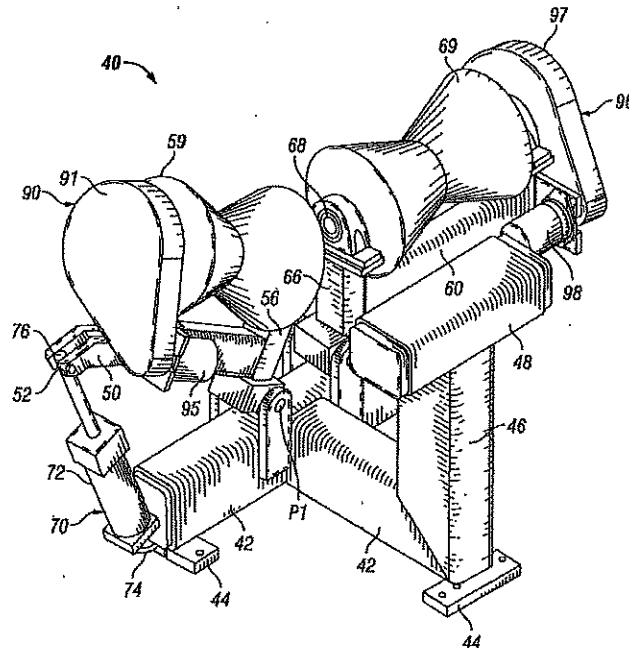



**THE REGISTRY OF PATENTS
SINGAPORE**

**THE PATENTS ACT
(CHAPTER 221)**

CERTIFICATE OF GRANT OF PATENT

In accordance with section 35 of the Patents Act, it is hereby certified that a patent having the P-No. 148984 has been granted in respect of an invention having the following particulars:

Title : PIPE ROLLER ASSEMBLY

Application Number : 200804979-3

Date of Filing : 02 July 2008

Priority Data : 2 July 2007 - PATENT APPLICATION NO.
11/824,640 (UNITED STATES OF AMERICA)

Name of Inventor(s) : KEVIN L. PRESTON; H. PAUL REINHARDT, JR.,;
LOREN D. SKILES

Name(s)
and Address(es) of
Proprietor(s) of Patent : CONTROL FLOW INC.
9201 FAIRBANKS NORTH HOUSTON ROAD
HOUSTON, TEXAS 77064
UNITED STATES OF AMERICA

Date of Grant : 15 March 2011

Dated this 15th day of March 2011.

**Liew Woon Yin (Ms)
Registrar of Patents
Singapore**



(11) **EP 2 011 959 B1**

(12) **EUROPEAN PATENT SPECIFICATION**

(45) Date of publication and mention of the grant of the patent:

→ **17.02.2021 Bulletin 2021/07**

(51) Int Cl.:

E21B 19/15^(2006.01)

(21) Application number: **08159415.2**

(22) Date of filing: **01.07.2008**

→ (54) **Pipe roller assembly**

Rohrrollenanordnung

Ensemble de suspension à rouleau

(84) Designated Contracting States:
**AT BE BG CH CY CZ DE DK EE ES FI FR GB GR
HR HU IE IS IT LI LT LU LV MC MT NL NO PL PT
RO SE SI SK TR**

(30) Priority: **02.07.2007 US 824640**

(43) Date of publication of application:
07.01.2009 Bulletin 2009/02

(73) Proprietor: **Control Flow Inc.**
Houston, TX 77064 (US)

(72) Inventors:
• **Preston, Kevin L.**
Tomball, TX 77377 (US)

• **Reinhardt, Jr., H. Paul**
Houston, TX 77065 (US)
• **Skiles, Loren D.**
Tomball, TX 77377 (US)

(74) Representative: **Barker Brettell LLP**
100 Hagley Road
Edgbaston
Birmingham B16 8QQ (GB)

(56) References cited:
US-A- 3 225 397 US-A- 3 257 881
US-A- 4 067 450 US-A- 4 067 453
US-A- 6 149 376 US-B1- 6 364 011

Note: Within nine months of the publication of the mention of the grant of the European patent in the European Patent Bulletin, any person may give notice to the European Patent Office of opposition to that patent, in accordance with the Implementing Regulations. Notice of opposition shall not be deemed to have been filed until the opposition fee has been paid. (Art. 99(1) European Patent Convention).



(12) PATENT

(19) NO

(11) 329534 ✓

(13) B1

NORGE

(51) Int Cl.
E21B 19/09 (2006.01)

Patentstyret

(21)	Søknadsnr	20035286	(86)	Int.inng.dag og søknadsnr	
(22)	Inng.dag	→ 2003.11.28	(85)	Videreføringdag	
(24)	Løpedag	2003.11.28	(30)	Prioritet	2002.12.09, US, 314747
(41)	Alm.tilgj	2004.06.10			
(45)	Meddelt	2010.11.08			
(73)	Innehaver	Control Flow Inc, 9201 Fairbanks North Houston Road, US-TX77064 HOUSTON, USA			
(72)	Oppfinner	Lacey C Coffey, Houston, TX, US-, USA Richard D Williams, Sugar Land, TX 77008, US-, USA			
(74)	Fullmektig	Acapo AS, Postboks 1880 Nordnes, 5817 BERGEN, Norge			

(54)	Benevnelse	Bærbar borestrengkompensator	✓(Portable Drill String Compensator)
(56)	Anførte publikasjoner	US4799827, US4638978, US3841607	
(57)	Sammendrag		

Det omtales et lukket borestrengkompensatorsystem med en hydraulisk fluidakkumulator, minst én lufttrykkbeholder, og et stempel og en stempelstang glidbart innkoblet i en sylinder. Borestrengkompensatoren frembringer strekkrefter for å støtte en borestreng og muliggjør at et borefartøy kan bli værende koblet til borestrengen under havnivåendringer forårsaker av bølgebevegelse eller hiv. I én utførelse omgir akkumulatoren sylindere og minst én lufttrykkbeholder er radialet anordnet rundt akkumulatoren og sylindere. I en annen utførelse omgir akkumulatoren sylindere og omfatter 2 porter, én port for å muliggjøre fluidkommunikasjon mellom sylindere og akkumulatoren og en andre port for å muliggjøre fluidkommunikasjon mellom akkumulatoren og lufttrykkbeholderen, hvor den første porten omfatter en avstengningsventil anordnet deri. Det er også omtalt en fremgangsmåte for kompensering av en borestreng.

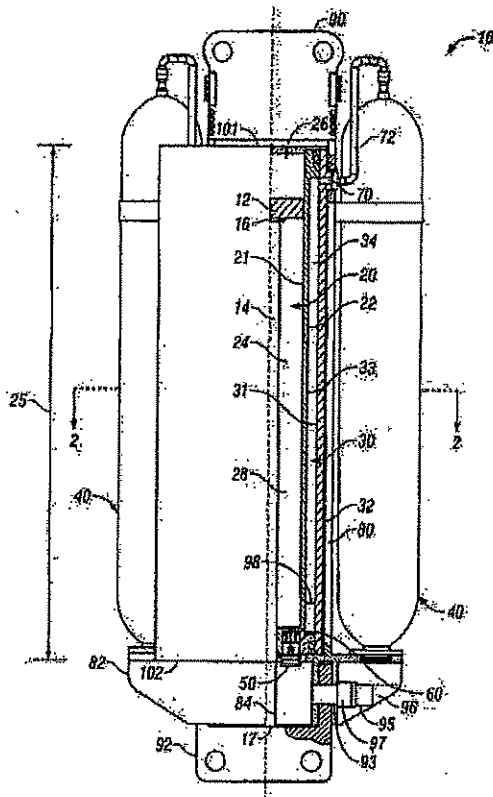



US006968900B2

(12) **United States Patent**
Williams et al.

(10) **Patent No.:** **US 6,968,900 B2**
(45) **Date of Patent:** **Nov. 29, 2005**

(54) **PORTABLE DRILL STRING COMPENSATOR**

(75) Inventors: **Richard D. Williams**, Sugar Land, TX (US); **Lacey C. Coffey**, Houston, TX (US)

(73) Assignee: **Control Flow Inc.**, Houston, TX (US)

(*) Notice: Subject to any disclaimer, the term of this patent is extended or adjusted under 35 U.S.C. 154(b) by 255 days.

4,317,586 A	3/1982	Campbell
4,362,438 A	12/1982	Spink
4,367,981 A	1/1983	Shapiro
4,379,657 A	4/1983	Widiner et al.
4,421,173 A	12/1983	Beakley et al.
4,423,983 A	1/1984	Dadiras et al.
4,432,420 A	2/1984	Gregory et al.
4,449,854 A	5/1984	Nayler
4,473,323 A	9/1984	Gregory
4,479,550 A	10/1984	Kühn et al.
4,487,150 A	12/1984	Shanks

(21) Appl. No.: **10/314,747**

(Continued)

(22) Filed: **Dec. 9, 2002**

FOREIGN PATENT DOCUMENTS

(65) **Prior Publication Data**

GB	2141470 A	12/1984
WO	WO 97/43516	11/1997
WO	WO 00/24998	5/2000

US 2004/0108117 A1 Jun. 10, 2004

(51) **Int. Cl.⁷** **E21B 43/01**

Primary Examiner—David Bagnell

(52) **U.S. Cl.** **166/355; 405/224.4; 405/224.3**

(74) *Attorney, Agent, or Firm*—Andrews Kurth LLP; Anthony F. Matheny

(58) **Field of Search** **166/355; 405/224.3, 405/224.4, 223.1, 224.1**

(57) **ABSTRACT**

(56) **References Cited**

U.S. PATENT DOCUMENTS

913,970 A	3/1909	Parfitt
3,208,728 A	9/1965	Parks
3,280,908 A	10/1966	Todd
3,313,345 A	4/1967	Fischer
3,643,751 A	2/1972	Crickmer
3,680,644 A	8/1972	Doughty
3,718,316 A	2/1973	Larralde et al.
3,793,835 A	2/1974	Larralde
3,804,183 A	4/1974	Duncan et al.
3,841,607 A	10/1974	Larralde et al.
3,897,045 A	7/1975	Butler
3,955,621 A	5/1976	Webb
4,004,532 A	1/1977	Reynolds
4,068,868 A	1/1978	Ohrt
4,075,858 A	2/1978	Frederick
4,176,722 A	12/1979	Wetmore et al.
4,215,950 A	8/1980	Stevenson
4,222,341 A	9/1980	Larsen et al.
4,272,059 A	6/1981	Noerager et al.

A closed system drill string compensator having a hydraulic fluid accumulator, at least one air pressure vessel, and a piston and a piston rod slidably engaged within a cylinder. The drill string compensator provides tensioning force for supporting a drill string and permits the drilling vessel to remain connected to the drill string during ocean level changes caused by wave action or ocean heave. In one embodiment, the accumulator surrounds the cylinder and at least one air pressure vessel is radially disposed around the accumulator and the cylinder. In another embodiment, the accumulator surrounds the cylinder and includes two ports, one port for permitting fluid communication between the cylinder and the accumulator and a second port for permitting fluid communication between the accumulator and the air pressure vessel, the first port including a shut-off valve disposed therein. Methods of compensating a drill string are also disclosed.

17 Claims, 3 Drawing Sheets

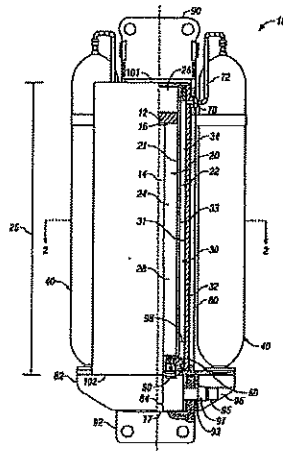

**THE REGISTRY OF PATENTS
SINGAPORE ✓**

**THE PATENTS ACT
(CHAPTER 221)**

CERTIFICATE OF GRANT OF PATENT

In accordance with section 35 of the Patents Act, it is hereby certified that a patent having the P-No. 115591 has been granted in respect of an invention having the following particulars:

Title : PORTABLE DRILL STRING COMPENSATOR

Application Number : 200306898-8

Date of Filing : 19 November 2003

Priority Data : 09 December 2002 - PATENT APPLICATION NO.
US 10/314,747 (UNITED STATES OF AMERICA)

Name of Inventor(s) : RICHARD D. WILLIAMS; LACEY C. COFFEY

Name(s) and Address(es) of Proprietor(s) of Patent : CONTROL FLOW, INC.
9201 FAIRBANKS NORTH HOUSTON ROAD
HOUSTON, TEXAS 77064
UNITED STATES OF AMERICA

Date of Grant : 31 August 2006

Dated this 31st day of August 2006.



Liew Woon Yin (Ms)
Registrar of Patents,
Singapore.

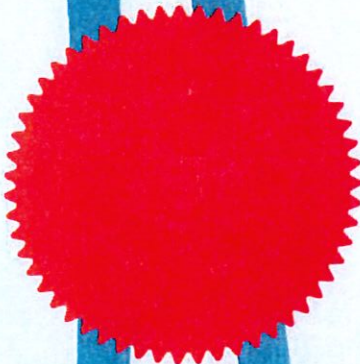



US007131496B2

(12) **United States Patent**
Williams et al.

(10) **Patent No.:** **US 7,131,496 B2**
(45) **Date of Patent:** ***Nov. 7, 2006**

(54) **PORTABLE DRILL STRING COMPENSATOR**

4,799,827 A * 1/1989 Jaqua 405/224.4
4,883,387 A * 11/1989 Myers et al. 405/224.4
5,392,853 A * 2/1995 Toon 166/187

(75) **Inventors:** **Richard D. Williams**, Sugar Land, TX (US); **Lacey C. Coffey**, Houston, TX (US)

OTHER PUBLICATIONS

(73) **Assignee:** **Control Flow Inc.**, Houston, TX (US)

U.S. Appl. Ser. No. 10/314,747, filed Dec. 9, 2002, last amended May 23, 2005.*

(*) **Notice:** Subject to any disclaimer, the term of this patent is extended or adjusted under 35 U.S.C. 154(b) by 0 days.

* cited by examiner

This patent is subject to a terminal disclaimer.

Primary Examiner—David Bagnell
Assistant Examiner—G M Collins
(74) *Attorney, Agent, or Firm*—Bracewell & Giuliani LLP; Anthony F. Matheny

(21) **Appl. No.:** **11/182,636**

(57) **ABSTRACT**

(22) **Filed:** **Jul. 15, 2005**

(65) **Prior Publication Data**

US 2005/0247452 A1 Nov. 10, 2005

Related U.S. Application Data

(63) Continuation of application No. 10/314,747, filed on Dec. 9, 2002, now Pat. No. 6,968,900.

A closed system drill string compensator having a hydraulic fluid accumulator, at least one air pressure vessel, and a piston and a piston rod slidably engaged within a cylinder. The drill string compensator provides tensioning force for supporting a drill string and permits the drilling vessel to remain connected to the drill string during ocean level changes caused by wave action or ocean heave. In one embodiment, the accumulator surrounds the cylinder and at least one air pressure vessel is radially disposed around the accumulator and the cylinder. In another embodiment, the accumulator surrounds the cylinder and includes two ports, one port for permitting fluid communication between the cylinder and the accumulator and a second port for permitting fluid communication between the accumulator and the air pressure vessel, the first port including a shut-off valve disposed therein. Methods of compensating a drill string are also disclosed.

(51) **Int. Cl.**
E21B 43/01 (2006.01)

(52) **U.S. Cl.** 166/355; 405/224.2; 405/224.3

(58) **Field of Classification Search** 166/355; 405/224.1, 224.3, 224.4, 223.1

See application file for complete search history.

(56) **References Cited**

U.S. PATENT DOCUMENTS

4,449,854 A * 5/1984 Naylor 405/195.1

14 Claims, 3 Drawing Sheets

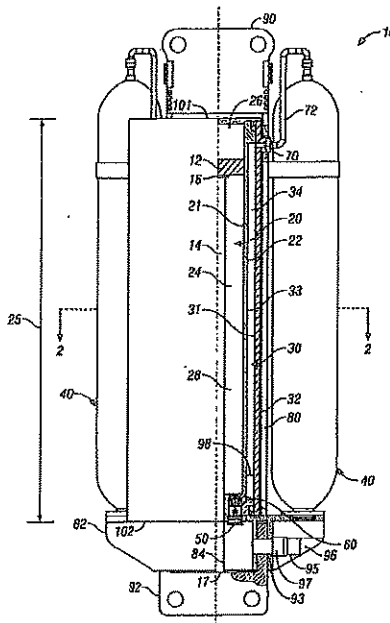



REPÚBLICA FEDERATIVA DO BRASIL
MINISTÉRIO DA INDÚSTRIA, COMÉRCIO EXTERIOR E SERVIÇOS
INSTITUTO NACIONAL DA PROPRIEDADE INDUSTRIAL

CARTA PATENTE Nº PI 0307860-4

O INSTITUTO NACIONAL DA PROPRIEDADE INDUSTRIAL concede a presente PATENTE DE INVENÇÃO

(21) Número do Depósito: PI 0307860-4

(22) Data do Depósito: 01/12/2003

(43) Data da Publicação do Pedido: 07/12/2004

(51) Classificação Internacional: E21B 19/09

(30) Prioridade Unionista: US 10/314,747 de 09/12/2002

(54) Título: COMPENSADOR PORTÁTIL DE COLUNA DE PERFURADOR E PROCESSO DE UTILIZAÇÃO DO MESMO (Portable Drill String Compensator) ✓

(73) Titular: CONTROL FLOW, INC. Endereço: 9201 Fairbanks North Houston Road, Houston, Texas 77064, ESTADOS UNIDOS DA AMÉRICA(US)

(72) Inventor: RICHARD D. WILLIAMS; LACEY C. COFFEY

Prazo de Validade: 10 (dez) anos contados a partir de 21/02/2017, observadas as condições legais ✓

Expedida em: 21 de Fevereiro de 2017.

Assinado digitalmente por:
Júlio César Castelo Branco Reis Moreira
Diretor de Patente

(19)



Europäisches Patentamt
European Patent Office
Office européen des brevets



(11)

EP 1 428 973 B1

(12)

EUROPEAN PATENT SPECIFICATION

(45) Date of publication and mention
of the grant of the patent:
31.05.2006 Bulletin 2006/22

(51) Int Cl.:
E21B 19/09 (2006.01)

(21) Application number: 03078680.0

(22) Date of filing: 19.11.2003

(54) **Portable heave compensator**

Tragbarer Tauschwingungskompensator
Compensateur de pilonnement portatif

(84) Designated Contracting States:
AT BE BG CH CY CZ DE DK EE ES FI FR GB GR
HU IE IT LI LU MC NL PT RO SE SI SK TR

• Coffey, Lacey C.
Houston, 77075 Texas (US)

(30) Priority: 09.12.2002 US 314747

(74) Representative: Newstead, Michael John et al
Page Hargrave
Southgate
Whitefriars
Lewins Mead
Bristol BS1 2NT (GB)

(43) Date of publication of application:
16.06.2004 Bulletin 2004/25

(73) Proprietor: Control Flow Inc.
Houston, TX 77064 (US)

(56) References cited:
US-A- 3 208 728 US-A- 3 804 183
US-A- 3 841 607 US-A- 4 449 854
US-A- 4 638 978 US-A- 4 799 827

(72) Inventors:
• Williams, Richard D.
Sugar Land, 77478 Texas (US)

EP 1 428 973 B1

Note: Within nine months from the publication of the mention of the grant of the European patent, any person may give notice to the European Patent Office of opposition to the European patent granted. Notice of opposition shall be filed in a written reasoned statement. It shall not be deemed to have been filed until the opposition fee has been paid. (Art. 99(1) European Patent Convention).



(12) PATENT

(19) NO

(11) 324759 ✓

(13) B1

NORGE

(51) Int Cl.
E21B 19/09 (2006.01)

Patentstyret

(21)	Søknadsnr	20035285	(86)	Int.inng.dag og søknadsnr	
(22)	Inng.dag	2003.11.28 ←	(85)	Videreføringdag	
(24)	Løpedag	2003.11.28	(30)	Prioritet	2002.12.09, US, 314710
(41)	Alm.tilgj	2004.06.10			
(45)	Meddelt	2007.12.10			
(73)	Innehaver	Control Flow Inc, 9201 Fairbanks North Houston Road, TX77064 HOUSTON, US			
(72)	Oppfinner	Lacey C Coffey, Houston, TX, US Richard D Williams, Sugar Land, TX 77008, US			
(74)	Fullmektig	Acapo AS, Postboks 1880 Nordnes, 5817 BERGEN			

(54)	Benevnelse	Strekkanordning med integrert hydraulisk fluidakkumulator
(56)	Anførte publikasjoner	US 3897045, US 4638978, US 5252004
(57)	Sammendrag	

Oppfinnelsen er rettet mot en strekksammenstilling for å frembringe strekk-krefter fra et flytende fartøy ved overflaten av havet til utblåsningssikrings-stack'en, eller produksjonstrect, som er koblet til brønnhoder på sjøbunnen. Strekksammenstillingen kompenserer for fartøybevegelser påført av bølgebevegelse og hiv og opprettholder et variabelt strekk på stigerørstrengen som reduserer mulighet for sammentrekning og således knekking eller feil på stigerørstrengen. Strekksammenstillingen ifølge oppfinnelsen omfatter en sylinder, et stopprør anordnet i sylindern og et slagstempel glidbart i kontakt med stopprøret. Strekksammenstillingen omfatter også minst ett gass- eller luft-overføringsrør for å frembringe et trykksatt luft-over-hydraulisk fluid-arrangement for å frembringe strekk-krefter til strekksammenstillingen.

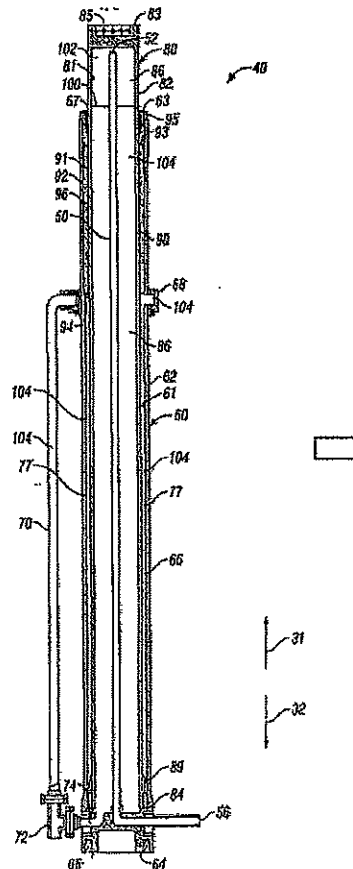



Europäisches Patentamt
European Patent Office
Office européen des brevets



(11) EP 1 428 971 B1

(12) EUROPEAN PATENT SPECIFICATION

(45) Date of publication and mention
of the grant of the patent:
03.05.2006 Bulletin 2006/18

(51) Int Cl.:
E21B 19/00 (2006.01)

(21) Application number: 03257691.0

(22) Date of filing: 08.12.2003

(54) Tensioner assembly having integral hydraulic fluid accumulator (Ram-Type) ✓
Spannanordnungsrichtung mit integrierter Druckmittelspeicher
Ensemble de tension ayant un accumulateur de fluide sous-pression intégré

(84) Designated Contracting States:
AT BE BG CH CY CZ DE DK EE ES FI FR GB GR
HU IE IT LI LU MC NL PT RO SE SI SK TR
Designated Extension States:
AL LT LV MK

(72) Inventors:
• Williams, Richard
Sugarland, Texas 77478 (US)
• Coffey, Lacey
Texas 77075 (US)

(30) Priority: 09.12.2002 US 314710

(74) Representative: Brown, David Leslie
HASLTINE LAKE,
Redcliff Quay
120 Redcliff Street
Bristol BS1 6HU (GB)

(43) Date of publication of application:
16.06.2004 Bulletin 2004/25

(73) Proprietor: Control Flow Inc.
Houston, TX 77064 (US)

(56) References cited:
US-A- 3 897 045 US-A- 4 638 978
US-A- 5 252 004

EP 1 428 971 B1

Note: Within nine months from the publication of the mention of the grant of the European patent, any person may give notice to the European Patent Office of opposition to the European patent granted. Notice of opposition shall be filed in a written reasoned statement. It shall not be deemed to have been filed until the opposition fee has been paid. (Art. 99(1) European Patent Convention).



US007008340B2

(12) **United States Patent**
Williams et al.

(10) **Patent No.:** **US 7,008,340 B2**
(45) **Date of Patent:** **Mar. 7, 2006**

- (54) **RAM-TYPE TENSIONER ASSEMBLY HAVING INTEGRAL HYDRAULIC FLUID ACCUMULATOR**
- (75) Inventors: **Richard D. Williams**, Sugar Land, TX (US); **Lacey C. Coffey**, Houston, TX (US)
- (73) Assignee: **Control Flow Inc.**, Houston, TX (US)
- (*) Notice: Subject to any disclaimer, the term of this patent is extended or adjusted under 35 U.S.C. 154(b) by 238 days.

3,804,183 A	4/1974	Duncan et al.
3,841,607 A	10/1974	Larralde et al.
3,897,045 A	7/1975	Butler
3,912,227 A *	10/1975	Meeker et al. 175/5
3,955,621 A	5/1976	Webb
4,004,532 A	1/1977	Reynolds
4,068,868 A	1/1978	Ohrt
4,075,858 A	2/1978	Frederick
4,176,722 A	12/1979	Wetmore et al.
4,215,950 A	8/1980	Stevenson
4,222,341 A	9/1980	Larsen et al.
4,272,059 A	6/1981	Noerager et al.
4,317,586 A	3/1982	Campbell

(21) Appl. No.: **10/314,710**

(Continued)

(22) Filed: **Dec. 9, 2002**

FOREIGN PATENT DOCUMENTS

(65) **Prior Publication Data**

FR 2484352 A1 * 12/1981

US 2004/0110589 A1 Jun. 10, 2004

(Continued)

- (51) **Int. Cl.**
F16H 7/08 (2006.01)
F16H 7/18 (2006.01)
F21B 29/12 (2006.01)
- (52) **U.S. Cl.** **474/101; 474/110; 166/355; 405/224.4**
- (58) **Field of Classification Search** **474/101, 474/110, 109; 175/5, 7, 8; 91/4 R, 4 A; 166/355, 350, 346, 367; 405/224.3, 224.2, 405/224.4**
See application file for complete search history.

Primary Examiner—Marcus Charles
(74) *Attorney, Agent, or Firm*—Andrews Kurth LLP; Anthony F. Matheny

(57) **ABSTRACT**

The invention is directed to a tensioner assembly for providing tensile force from a floating vessel at the surface of the ocean to the blowout preventer stack, or production tree, which is connected to the wellhead at the sea floor. The tensioner assembly compensates for vessel motion induced by wave action and heave and maintains a variable tension to the riser string alleviating the potential for compression and thus buckling or failure of the riser string. The tensioner assembly of the present invention includes a cylinder, a stop tube disposed with the cylinder, and a ram slidably engaged within the stop tube. The tensioner assembly also includes at least one gas, or air, transfer tube to create a pressurized air over hydraulic fluid arrangement to provide tensile force to the tensioner assembly.

(56) **References Cited**
U.S. PATENT DOCUMENTS

913,970 A	3/1909	Parfitt
1,815,907 A *	7/1931	Halstead et al. 91/4 R
3,208,728 A	9/1965	Parks
3,280,908 A	10/1966	Todd
3,313,345 A	4/1967	Fischer
3,643,751 A	2/1972	Crickmer
3,680,644 A	8/1972	Doughty
3,718,316 A	2/1973	Larralde et al.
3,793,835 A	2/1974	Larralde

6 Claims, 4 Drawing Sheets

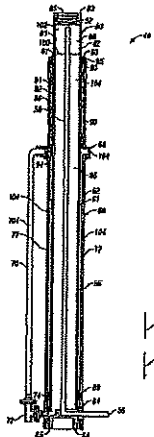

s
x
n
e
e
!

**THE REGISTRY OF PATENTS
SINGAPORE**

THE PATENTS ACT
(CHAPTER 221)

CERTIFICATE OF GRANT OF PATENT

In accordance with section 35 of the Patents Act, it is hereby certified that a patent having the P-No. 125097 has been granted in respect of an invention having the following particulars:

Title : RAM-TYPE TENSIONER ASSEMBLY HAVING
INTEGRAL HYDRAULIC FLUID
ACCUMULATOR

Application Number : 200306913-5

Date of Filing : 19 November 2003

Priority Data : 9 December 2002 - PATENT APPLICATION NO.
US 10/314,710 (UNITED STATES OF AMERICA)

Name of Inventor(s) : RICHARD D. WILLIAMS; LACEY C. COFFEY

Name(s)
and Address(es) of
Proprietor(s) of Patent : CONTROL FLOW, INC.
9201 FAIRBANKS NORTH HOUSTON ROAD
HOUSTON, TEXAS 77064
UNITED STATES OF AMERICA

Date of Grant : 31 October 2006

Dated this 31st day of October 2006.



Liew Woon Yin (Ms)
Registrar of Patents,
Singapore

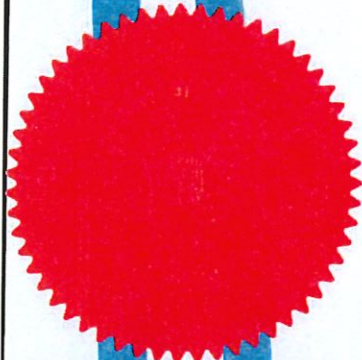



US007131922B2

(12) **United States Patent**
Williams et al.

(10) **Patent No.:** **US 7,131,922 B2**
(45) **Date of Patent:** **Nov. 7, 2006**

- (54) **RAM-TYPE TENSIONER ASSEMBLY HAVING INTEGRAL HYDRAULIC FLUID ACCUMULATOR**
- (75) **Inventors:** **Richard D. Williams, Sugar Land, TX (US); Lacey C. Coffey, Houston, TX (US)**
- (73) **Assignee:** **Control Flow Inc., Houston, TX (US)**

3,841,607 A *	10/1974	Larralde et al.	254/392
3,912,227 A *	10/1975	Meeker et al.	254/271
3,955,621 A *	5/1976	Webb	166/355
4,272,059 A *	6/1981	Noerager et al.	254/392
4,432,420 A *	2/1984	Gregory et al.	166/355
4,479,550 A *	10/1984	Kuhn et al.	173/112
4,638,978 A *	1/1987	Jordan	254/228

(*) **Notice:** Subject to any disclaimer, the term of this patent is extended or adjusted under 35 U.S.C. 154(b) by 0 days.

FOREIGN PATENT DOCUMENTS

WO WO 97/43516 A1 * 11/1997

(21) **Appl. No.:** **11/368,076**

(22) **Filed:** **Mar. 3, 2006**

(65) **Prior Publication Data**
US 2006/0154764 A1 Jul. 13, 2006

Related U.S. Application Data

(62) Division of application No. 10/314,710, filed on Dec. 9, 2002, now Pat. No. 7,008,340.

(51) **Int. Cl.**
F16H 7/08 (2006.01)
F16H 7/18 (2006.01)
F21B 29/12 (2006.01)

(52) **U.S. Cl.** **474/101; 474/110; 165/355; 405/224.5**

(58) **Field of Classification Search** **474/109-110, 474/101, 117; 405/224.3, 224.4; 166/346, 166/350, 367, 355; 175/5-6**
See application file for complete search history.

(56) **References Cited**

U.S. PATENT DOCUMENTS

1,815,907 A * 7/1931 Halstead et al. 91/4 R

* cited by examiner

Primary Examiner—Marcus Charles
(74) *Attorney, Agent, or Firm*—Bracewell & Giuliani LLP; Anthony F. Matheny

(57) **ABSTRACT**

The invention is directed to a tensioner assembly for providing tensile force from a floating vessel at the surface of the ocean to the blowout preventer stack, or production tree, which is connected to the wellhead at the sea floor. The tensioner assembly compensates for vessel motion induced by wave action and heave and maintains a variable tension to the riser string alleviating the potential for compression and thus buckling or failure of the riser string. The tensioner assembly of the present invention includes a cylinder, a stop tube disposed with the cylinder, and a ram slidably engaged within the stop tube. The tensioner assembly also includes at least one gas, or air, transfer tube to create a pressurized air over hydraulic fluid arrangement to provide tensile force to the tensioner assembly.

17 Claims, 4 Drawing Sheets

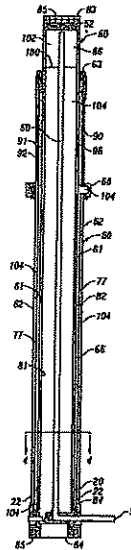

5
7
1
-
2
3
1



REPÚBLICA FEDERATIVA DO BRASIL
MINISTÉRIO DO DESENVOLVIMENTO, INDÚSTRIA E COMÉRCIO EXTERIOR
INSTITUTO NACIONAL DA PROPRIEDADE INDUSTRIAL

CARTA PATENTE Nº PI 0306552-9

O INSTITUTO NACIONAL DA PROPRIEDADE INDUSTRIAL concede a presente PATENTE DE INVENÇÃO, que outorga ao seu titular a propriedade da invenção caracterizada neste título, em todo o território nacional, garantindo os direitos dela decorrentes, previstos na legislação em vigor.

(21) Número do Depósito: PI 0306552-9 ←

(22) Data do Depósito: 04/12/2003

(43) Data da Publicação do Pedido: 05/10/2004

(51) Classificação Internacional: E21B 17/00

(30) Prioridade Unionista: 09/12/2002 US 10/314,710

(54) Título: CONJUNTO TENSOR TIPO ÊMBOLO COM ACUMULADOR DE FLUIDO HIDRÁULICO INTEGRADO

(73) Titular: CONTROL FLOW, INC. Endereço: 9201 Fairbanks North Houston Road, Houston, Texas 77064, Estados Unidos (US).

(72) Inventor: RICHARD D. WILLIAMS

Prazo de Validade: 10 (dez) anos contados a partir de 13/01/2015, observadas as condições legais.

Expedida em: 13 de Janeiro de 2015. ←

Assinado digitalmente por:

Liane Elizabeth Caldeira Lage
Diretora de Patentes Substituta



US006834723B2

(12) **United States Patent**
Jordan

(10) **Patent No.:** **US 6,834,723 B2**
(45) **Date of Patent:** **Dec. 28, 2004**

→ (54) **SYSTEM AND METHOD FOR RISER RECOIL CONTROL**

(75) **Inventor:** Larry Russell Jordan, Houston, TX (US)

(73) **Assignee:** Cooper Cameron Corporation, Houston, TX (US)

(*) **Notice:** Subject to any disclaimer, the term of this patent is extended or adjusted under 35 U.S.C. 154(b) by 64 days.

(21) **Appl. No.:** 10/258,512

(22) **PCT Filed:** Apr. 27, 2001

(86) **PCT No.:** PCT/US01/13800

§ 371 (c)(1),
(2), (4) **Date:** Oct. 24, 2002

(87) **PCT Pub. No.:** WO01/81164

PCT Pub. Date: Nov. 1, 2001

(65) **Prior Publication Data**

US 2003/0205382 A1 Nov. 6, 2003

Related U.S. Application Data

(60) Provisional application No. 60/200,398, filed on Apr. 27, 2000.

(51) **Int. Cl.⁷** E21B 19/09

(52) **U.S. Cl.** 166/355; 114/264; 166/367; 175/5

(58) **Field of Search** 175/5, 7; 166/355, 166/354, 367; 114/264; 405/224.1, 224.2, 224.3, 224.4, 195.1

(56) **References Cited**

U.S. PATENT DOCUMENTS

4,351,261 A	9/1982	Shanks	114/264
4,487,150 A *	12/1984	Shanks	114/264
5,846,028 A	12/1998	Thory	405/195.1
5,978,739 A	11/1999	Stockton	702/6

* cited by examiner

Primary Examiner—William Nender

(74) *Attorney, Agent, or Firm*—Michael P. Hartman; Peter J. Bielinski

(57) **ABSTRACT**

A riser recoil control system (10) adjusts tension forces (F1, F2) applied to a marine riser (60), which is attached to an anchored, floating vessel (30) and a wellhead (80). The riser (60) is attached to the vessel (30) using tension forces (F1, F2) asserted by riser tensioners (20). Each tensioner (20) has an air shutoff valve (110), and an orifice-controlled fluid valve (120). A disconnection sensing means (200) provides a disconnect signal when the riser (60) is disconnected from the wellhead (80), which closes the valves (110, 120) and adjusts the tension forces (F1, F2) applied by the tensioners (20). The invention includes a method for adjusting the tension forces (F1, F2) applied to the riser (60), including sensing the disconnect signal and adjusting the tension forces (F1, F2) supplied to the riser (60) by closing the air shutoff valves (110) and partially closing the orifice-controlled fluid valves (120).

12 Claims, 3 Drawing Sheets

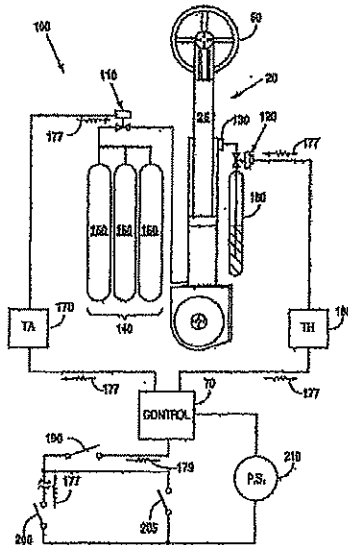



(12) PATENT

✓ Tensioner/Slip Joint Assembly

(19) NO

(11) 330547

(13) B1

NORGE

(51) Int Cl.
E21B 19/00 (2006.01)

Patentstyret

(21)	Søknadsnr	20025469	(86)	Int.inng.dag og søknadsnr	2001.06.14 PCT/US2001/19371
(22)	Inng.dag	2002.11.15	(85)	Videreføringssdag	2002.11.15
(24)	Løpedag	2001.06.14 ←	(30)	Prioritet	2000.06.15, US, 211652
(41)	Alm.tilgj	2003.02.12			
(45)	Meddelt	2011.05.16			
(73)	Innehaver	Control Flow Inc, 9201 Fairbanks North Houston Road, TX77064 HOUSTON, USA			
(72)	Oppfinner	Graeme E Reynolds, 2053 Western Village, Houston, TX 77043, USA			
(74)	Fullmektig	Acapo AS, Postboks 1880 Nordnes, 5817 BERGEN, Norge			

(54)	Benevnelse	Anordning ved glidekobling
(56)	Anførte publikasjoner	US 4712620 A, US 5846028 A, US 5951061 A, US 4068868 A, US 5727630 A
(57)	Sammendrag	

Oppfinnelsen vedrører en strekk/glideskjøtmodul for å frembringe en rørledning fra et drivende fartøy på havets overflate til utblåsningssikringen, eller produksjonstreet, som er koblet til brønnhodet på havbunnen. Strekk/glide- skjøtmodulen (30) kompensere for fartøyets bevegelse forårsaket av bølgenes påvirkning og løft og opprettholder en variabel strekk på stigerørsstrengen, som reduserer potensialet for kompresjon og således knekking eller sammenbrudd av stigerørsstrengen. Strekk/glideskjøtmodulen (30) i foreliggende oppfinnelse omfatter foretrukket minst en røropphengsføring (40) med minst en opphengsring (45); minst en øvre fleksibel dreieskjøtsammenstilling (50), minst en manifold med radiale åpninger (60), minst en strekksylinder (70) og minst en glideskjøtsammenstilling (90), satt sammen som en enhet.

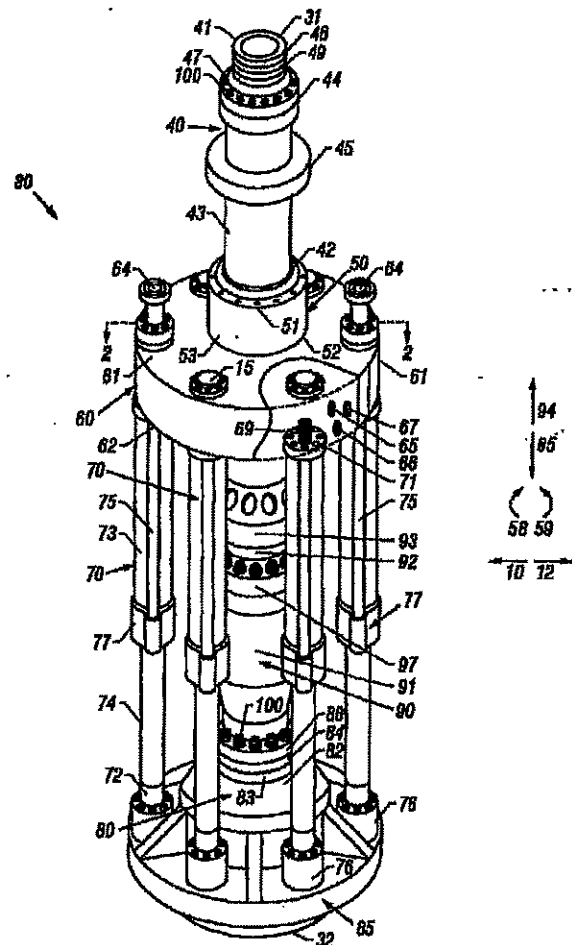



US006739395B2

(12) **United States Patent**
Reynolds

(10) **Patent No.:** **US 6,739,395 B2**
(45) **Date of Patent:** ***May 25, 2004**

- (54) **TENSIONER/SLIP-JOINT ASSEMBLY**
- (75) **Inventor:** Graeme E. Reynolds, Houston, TX (US)
- (73) **Assignee:** Control Flow Inc., Houston, TX (US)
- (*) **Notice:** Subject to any disclaimer, the term of this patent is extended or adjusted under 35 U.S.C. 154(b) by 0 days.

This patent is subject to a terminal disclaimer.

3,848,668 A	*	11/1974	Sizer et al.	166/72
3,871,456 A	*	3/1975	Sizer et al.	166/298
3,917,006 A	*	11/1975	Kellner	175/5
3,955,621 A	*	5/1976	Webb	166/355
4,120,362 A	*	10/1978	Chateau et al.	166/339
4,142,584 A	*	3/1979	Brewer et al.	166/359
4,215,950 A	*	8/1980	Stevenson	405/168.4
4,317,586 A	*	3/1982	Campbell	285/95
4,367,981 A	*	1/1983	Shapiro	405/224.2
4,379,657 A	*	4/1983	Widiner et al.	405/224.4
4,712,620 A	*	12/1987	Lim et al.	166/355
4,787,778 A	*	11/1988	Myers et al.	405/224.4
4,808,035 A	*	2/1989	Stanton et al.	405/224.4
4,883,387 A	*	11/1989	Myers et al.	405/224.4
6,419,277 B1	*	7/2002	Reynolds	285/123.1

* cited by examiner

Primary Examiner—Robert E. Pezzuto
Assistant Examiner—Thomas A Beach
(74) *Attorney, Agent, or Firm*—Anthony F. Matheny; Andrews Kurth LLP

- (21) **Appl. No.:** 10/342,996
- (22) **Filed:** Jan. 15, 2003
- (65) **Prior Publication Data**
US 2003/0102134 A1 Jun. 5, 2003

Related U.S. Application Data

- (63) Continuation of application No. 09/881,139, filed on Jun. 14, 2001, now Pat. No. 6,530,430.
- (60) Provisional application No. 60/211,652, filed on Jun. 15, 2000.
- (51) **Int. Cl.⁷** E21B 29/12; E21B 12/01
- (52) **U.S. Cl.** 166/346; 166/355; 166/367
- (58) **Field of Search** 166/350, 359, 166/367, 355, 346; 405/224.4, 224.2

(56) **References Cited**

U.S. PATENT DOCUMENTS

3,280,908 A	*	10/1966	Todd	166/340
3,313,345 A	*	4/1967	Fisher	166/355
3,646,996 A	*	3/1972	Pearce, Jr.	166/212

(57) **ABSTRACT**

The invention is directed to a tensioner/slip-joint module for providing a conduit from a floating vessel at the surface of the ocean to the blowout preventer stack, or production tree, which is connected to the wellhead at the sea floor. The tensioner/slip-joint module compensates for vessel motion induced by wave action and heave and maintains a variable tension to the riser string alleviating the potential for compression and thus buckling or failure of the riser string. The tensioner/slip-joint module of the present invention preferably includes at least one mandrel having at least one hang-off donut; at least one upper flexjoint swivel assembly, at least one radially ported manifold, at least one tensioning cylinder, and at least one slip-joint assembly combined in a single unit.

24 Claims, 5 Drawing Sheets

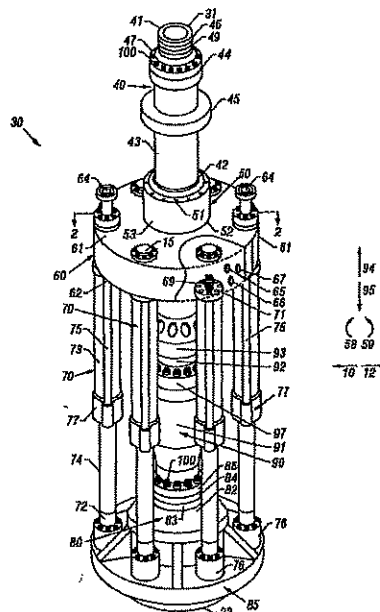



US006530430B2

(12) **United States Patent**
Reynolds

(10) **Patent No.:** **US 6,530,430 B2**
(45) **Date of Patent:** **Mar. 11, 2003**

- (54) **TENSIONER/SLIP-JOINT ASSEMBLY**
- (75) **Inventor:** **Graeme E. Reynolds, Houston, TX (US)**
- (73) **Assignee:** **Control Flow Inc., Houston, TX (US)**
- (*) **Notice:** Subject to any disclaimer, the term of this patent is extended or adjusted under 35 U.S.C. 154(b) by 30 days.

4,615,542 A	10/1986	Iđeno et al.	
4,712,620 A	12/1987	Lim et al.	
4,787,778 A	* 11/1988	Myers et al.	166/367
4,808,035 A	* 2/1989	Stanton et al.	166/355
4,883,387 A	* 11/1989	Myers et al.	166/367
5,727,630 A	3/1998	Brammer	
5,846,028 A	12/1998	Thory	
5,951,061 A	9/1999	Arlt, III et al.	
6,419,277 B1	* 7/2002	Reynolds	166/367

FOREIGN PATENT DOCUMENTS

- (21) **Appl. No.:** **09/881,139**
- (22) **Filed:** **Jun. 14, 2001**
- (65) **Prior Publication Data**

GB	2141470 A	12/1984
WO	WO 97/43516	11/1997
WO	WO 00/24998	5/2000

* cited by examiner

US 2002/0000321 A1 Jan. 3, 2002

Related U.S. Application Data

- (60) Provisional application No. 60/211,652, filed on Jun. 15, 2000.
- (51) **Int. Cl.⁷** **E21B 29/12; E21B 12/01**
- (52) **U.S. Cl.** **166/346; 166/355; 166/367**
- (58) **Field of Search** **166/350, 359, 166/367, 355, 346; 405/224.4, 224.2**

Primary Examiner—Thomas B. Will
Assistant Examiner—Thomas A. Beach
 (74) *Attorney, Agent, or Firm*—Andrews & Kurth L.L.P.;
 Anthony F. Matheny

(57) **ABSTRACT**

A tensioner/slip-joint module for providing a conduit from a floating vessel at the surface of the ocean to the blowout preventer stack, or production tree, which is connected to the wellhead at the sea floor. The tensioner/slip-joint module compensates for vessel motion induced by wave action and heave and maintains a variable tension to the riser string alleviating the potential for compression and thus buckling or failure of the riser string. The tensioner/slip-joint module preferably includes at least one mandrel having at least one hang-off donut; at least one upper flexjoint swivel assembly, at least one radially ported manifold, at least one tensioning cylinder, and at least one slip-joint assembly combined in a single unit.

(56) **References Cited**

U.S. PATENT DOCUMENTS

3,280,908 A	* 10/1966	Todd	166/340
3,313,345 A	* 4/1967	Fischer	166/355
3,643,751 A	2/1972	Crickmer	
3,955,621 A	* 5/1976	Webb	166/355
4,068,868 A	1/1978	Ohrt	
4,215,950 A	* 8/1980	Stevenson	114/264
4,317,586 A	* 3/1982	Campbell	285/145.4
4,367,981 A	* 1/1983	Shapiro	166/355
4,379,657 A	* 4/1983	Widiner et al.	405/168.4

24 Claims, 5 Drawing Sheets

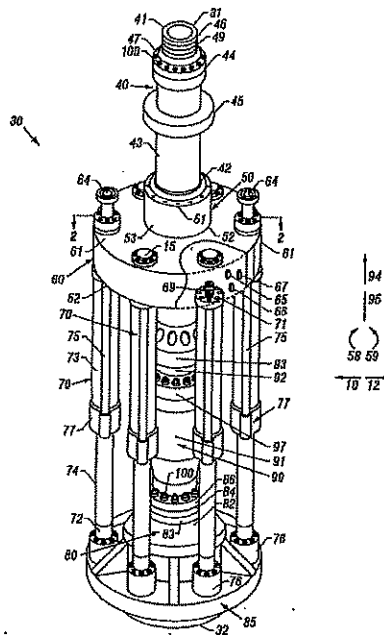

**THE REGISTRY OF PATENTS
SINGAPORE**

**THE PATENTS ACT
(CHAPTER 221)**

CERTIFICATE OF GRANT OF PATENT

In accordance with section 35 of the Patents Act, it is hereby certified that a patent having the P-No. 93649 [WO 01/96706] has been granted in respect of an invention having the following particulars:

Title : TENSIONER/SLIP-JOINT ASSEMBLY

Application Number : 200207553-9

Date of Filing : 14 June 2001

Priority Data : 15 June 2000 - PATENT APPLICATION NO.
60/211,652 (UNITED STATES OF AMERICA)

Name of Inventor(s) : REYNOLDS, GRAEME, E.

Name(s) and Address(es) of
Proprietor(s) of Patent : CONTROL FLOW, INC.
9201 FAIRBANKS N. HOUSTON ROAD,
HOUSTON, TEXAS 77064
UNITED STATES OF AMERICA

Date of Grant : 31 January 2005

Dated this 31st day of January 2005.

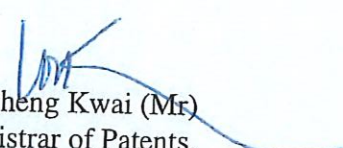
Wong Sheng Kwai (Mr)
Acting Registrar of Patents,
Singapore.



SUOMI - FINLAND
(FI)

PATENTTI- JA REKISTERIHALLITUS
PATENT- OCH REGISTERSTYRELSEN

✓ Tensioner/Slip-Joint Assembly

- (12) EUROOPAN PATENTTIJULKAISUN KÄÄNNÖS
ÖVERSÄTTNING AV EUROPEISK PATENTSKRIFT
- (10) FI/EP1295009 T3
- (45) Käännöksen kuuli. pvm - Övers. kungörelsedag 14.07.2006
- (80) Euroopan patentin myöntämispäivä -
Meddelandedatum för det europeiska patentet ✓ 29.03.2006
- (51) Kv.lk. - Int.kl.
E21B 19/00 (2006.01)
- (86) Euroopan patentihakemus - Europeisk patentansökan EP01948420.3
- (86) (24) Alkupaivä - Löpdag 14.06.2001
- (87) EP-hakemuksen julkiseksi tulo pvm -
EP-ansökans publiceringsdag 26.03.2003
- (86) Kv. hakemus - Int. ansökan PCT/ US2001019371
- (30) Etuoikeus - Prioritet
15.06.2000 US 211652 P

(73) Haltija - Innehavare

1 •Control Flow Inc., 9201 Fairbanks N. Houston Road, Houston, TX 77064, AMERIKAN YHDYSVALLAT, (US)

(72) Keksijä - Uppfinnare

1 •REYNOLDS, Graeme, E., 2053 Western Village, Houston, TX 77043, AMERIKAN YHDYSVALLAT, (US)

(74) Asiamies - Ombud: Papula Oy
Mechelininkatu 1 a, 00180 Helsinki

(54) Keksinnön nimitys - Uppfinningens benämning

Kirstin/liukuliitoskokonaisuus
Spänningsanordning / glidförbandsuppsättning

(56) Viitejulkaisut - Anförda publikationer

WO-A 00/24998, WO-A 97/43516, GB-A 2141470, US-A 3643751, US-A 4068868, US-A 4615542, US-A 4712620, US-A 5727630,
US-A 5846028, US-A 5951061



REPÚBLICA FEDERATIVA DO BRASIL



Ministério do Desenvolvimento, Indústria e Comércio Exterior
Instituto Nacional da Propriedade Industrial

CARTA PATENTE N.º PI0111376-3 *Patente de Invenção*

O INSTITUTO NACIONAL DA PROPRIEDADE INDUSTRIAL concede a presente PATENTE, que outorga ao seu titular a propriedade da invenção caracterizada neste título, em todo o território nacional, garantindo os direitos dela decorrentes, previstos na legislação em vigor.

(21) Número do Depósito : PI0111376-3

(22) Data do Depósito : 14/06/2001

(43) Data da Publicação do Pedido : 20/12/2001

(51) Classificação Internacional : E21B 19/00

(30) Prioridade Unionista : 15/06/2000 US 60/211,652

(54) Título : CONJUNTO TENSOR/JUNTA DESLIZANTE.
✓ (Tensioner/Slip-Joint Assembly)

(73) Titular : Control Flow, Inc., Endereço: 9201 Fairbanks North Houston Road, Houston, Texas 77064, Estados Unidos (US).

(72) Inventor : Graeme E. Reynolds, Endereço: 2053 Western Village, Houston, TX 77043, Estados Unidos.

Prazo de Validade : 10 (dez) anos contados a partir de 06/09/2011, observadas as condições legais.

Expedida em : 6 de Setembro de 2011.

Júlio César Castelo Branco Reis Moreira
Diretor de Patentes





Europäisches Patentamt
 European Patent Office
 Office européen des brevets



(11) **EP 1 295 009 B1**

(12) **EUROPEAN PATENT SPECIFICATION**

(45) Date of publication and mention
 of the grant of the patent:
29.03.2006 Bulletin 2006/13

(51) Int Cl.:
E21B 19/00 (2006.01)

(21) Application number: **01948420.3**

(86) International application number:
PCT/US2001/019371

(22) Date of filing: **14.06.2001**

(87) International publication number:
WO 2001/096706 (20.12.2001 Gazette 2001/51)

(54) **TENSIONER/SLIP-JOINT ASSEMBLY**

TELESKOPISCHE SPANNVORRICHTUNG FÜR EINE STEIGROHRVERBINDUNG

ASSEMBLAGE JOINT COULISSANT/TENSIONNEUR

(84) Designated Contracting States:
**AT BE CH CY DE DK ES FI FR GB GR IE IT LI LU
 MC NL PT SE TR**

(74) Representative: **Newstead, Michael John et al**
Page Hargrave
Southgate
Whitefriars
Lewins Mead
Bristol BS1 2NT (GB)

(30) Priority: **15.06.2000 US 211652 P**

(43) Date of publication of application:
26.03.2003 Bulletin 2003/13

(56) References cited:
WO-A-00/24998 **WO-A-97/43516**
GB-A- 2 141 470 **US-A- 3 643 751**
US-A- 4 068 868 **US-A- 4 615 542**
US-A- 4 712 620 **US-A- 5 727 630**
US-A- 5 846 028 **US-A- 5 951 061**

(73) Proprietor: **Control Flow Inc.**
Houston, TX 77064 (US)

(72) Inventor: **REYNOLDS, Graeme, E.**
Houston, TX 77043 (US)

EP 1 295 009 B1

Note: Within nine months from the publication of the mention of the grant of the European patent, any person may give notice to the European Patent Office of opposition to the European patent granted. Notice of opposition shall be filed in a written reasoned statement. It shall not be deemed to have been filed until the opposition fee has been paid. (Art. 99(1) European Patent Convention).



REPÚBLICA FEDERATIVA DO BRASIL
MINISTÉRIO DO DESENVOLVIMENTO, INDÚSTRIA E COMÉRCIO EXTERIOR
INSTITUTO NACIONAL DA PROPRIEDADE INDUSTRIAL

CARTA PATENTE Nº PI 0306552-9

O INSTITUTO NACIONAL DA PROPRIEDADE INDUSTRIAL concede a presente PATENTE DE INVENÇÃO, que outorga ao seu titular a propriedade da invenção caracterizada neste título, em todo o território nacional, garantindo os direitos dela decorrentes, previstos na legislação em vigor.

(21) Número do Depósito: PI 0306552-9 ←

(22) Data do Depósito: 04/12/2003

(43) Data da Publicação do Pedido: 05/10/2004

(51) Classificação Internacional: E21B 17/00

(30) Prioridade Unionista: 09/12/2002 US 10/314,710

(54) Título: CONJUNTO TENSOR TIPO ÊMBOLO COM ACUMULADOR DE FLUIDO HIDRÁULICO INTEGRADO

(73) Titular: CONTROL FLOW, INC. Endereço: 9201 Fairbanks North Houston Road, Houston, Texas 77064, Estados Unidos (US).

(72) Inventor: RICHARD D. WILLIAMS

Prazo de Validade: 10 (dez) anos contados a partir de 13/01/2015, observadas as condições legais.

Expedida em: 13 de Janeiro de 2015. ←

Assinado digitalmente por:

Liane Elizabeth Caldeira Lage
Diretora de Patentes Substituta



US010156115B2

(12) **United States Patent**
Irvine et al.

(10) **Patent No.:** US 10,156,115 B2
(45) **Date of Patent:** Dec. 18, 2018

(54) **WEIGHT SET MANDREL AND TUBING HANGER**

USPC 166/382
See application file for complete search history.

(71) Applicants: **Jock W. Irvine**, Houston, TX (US);
Thomas M. Lambert, Houston, TX (US)

(56) **References Cited**

U.S. PATENT DOCUMENTS

(72) Inventors: **Jock W. Irvine**, Houston, TX (US);
Thomas M. Lambert, Houston, TX (US)

4,421,164 A *	12/1983	Galle, Jr.	E21B 33/04 166/118
4,836,288 A *	6/1989	Wester	E21B 33/043 166/340
6,241,023 B1 *	6/2001	Krauss	E21B 23/06 166/125
2005/0023866 A1 *	2/2005	Matussek	E21B 23/04 296/210
2008/0135229 A1 *	6/2008	Hunter	E21B 33/04 166/84.1
2014/0262349 A1 *	9/2014	Turley	E21B 23/06 166/387

(73) Assignee: **CONTROL FLOW, INC.**, Houston, TX (US)

(*) Notice: Subject to any disclaimer, the term of this patent is extended or adjusted under 35 U.S.C. 154(b) by 133 days.

(21) Appl. No.: **15/257,700**

* cited by examiner

(22) Filed: **Sep. 6, 2016**

Primary Examiner — Taras P Bemko

(65) **Prior Publication Data**

US 2017/0067307 A1 Mar. 9, 2017

Related U.S. Application Data

(60) Provisional application No. 62/214,754, filed on Sep. 4, 2015.

(57) **ABSTRACT**

An improved weight-set hanger system and method of securing the weight set hanger for use comprises three independent locking mechanisms that are built into an actuator/packoff assembly. These independent locking mechanisms comprise two locking rings, one of which fastens the actuator/packoff assembly to a spool body, and the other of which internally locks the hanger to the actuator/packoff assembly. A third locking mechanism comprises a plurality of screw down spring loaded lock pin assemblies, which, in an embodiment, are spaced out at 90 degree intervals.

(51) **Int. Cl.**
E21B 33/04 (2006.01)
E21B 23/01 (2006.01)

(52) **U.S. Cl.**
CPC *E21B 33/04* (2013.01); *E21B 23/01* (2013.01)

(58) **Field of Classification Search**
CPC E21B 33/04; E21B 23/01

10 Claims, 2 Drawing Sheets

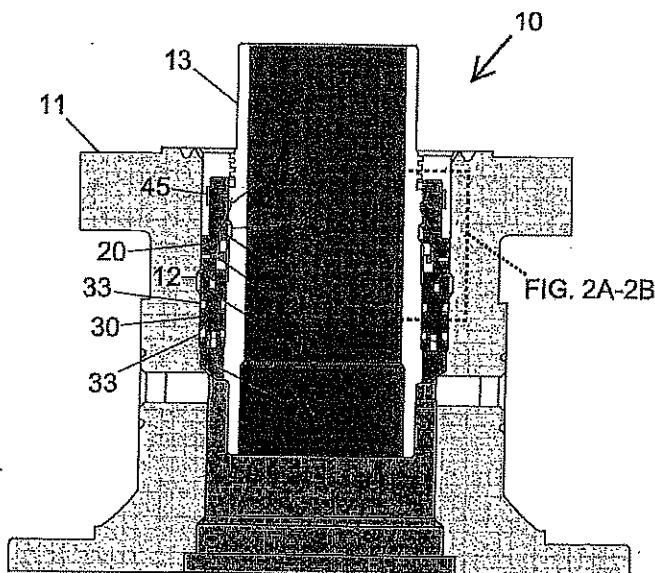



(11) **EP 3 344 847 B1**

(12) **EUROPEAN PATENT SPECIFICATION**

(45) Date of publication and mention of the grant of the patent:
28.07.2021 Bulletin 2021/30

(51) Int Cl.:
E21B 23/01^(2006.01) E21B 23/02^(2006.01)
E21B 33/04^(2006.01) E21B 43/10^(2006.01)

(21) Application number: **16843197.1**

(86) International application number:
PCT/US2016/050433

(22) Date of filing: **06.09.2016**

(87) International publication number:
WO 2017/041108 (09.03.2017 Gazette 2017/10)

(54) **WEIGHT-SET MANDREL AND TUBING HANGER**

AUFHÄNGER MIT EINGESTELTEM GEWICHT FÜR DORN UND ROHR
MANDRIN ENSEMBLE DE POIDS ET SUSPENSION DE TUBULURE

(84) Designated Contracting States:
AL AT BE BG CH CY CZ DE DK EE ES FI FR GB
GR HR HU IE IS IT LI LT LU LV MC MK MT NL NO
PL PT RO RS SE SI SK SM TR

• **LAMBERT, Thomas, M**
Houston, TX 77073 (US)

(30) Priority: **04.09.2015 US 201562214754 P**

(74) Representative: **Barker Brettell LLP**
100 Hagley Road
Edgbaston
Birmingham B16 8QQ (GB)

(43) Date of publication of application:
11.07.2018 Bulletin 2018/28

(73) Proprietor: **Control Flow Inc.**
Houston, TX 77064 (US)

(56) References cited:
US-A- 3 924 678 US-A- 4 421 164
US-A- 4 836 288 US-A- 4 836 288
US-A1- 2005 023 866 US-A1- 2008 135 229

(72) Inventors:
• **IRVINE, Jock, W**
Houston, TX 77065 (US)

EP 3 344 847 B1

Note: Within nine months of the publication of the mention of the grant of the European patent in the European Patent Bulletin, any person may give notice to the European Patent Office of opposition to that patent, in accordance with the Implementing Regulations. Notice of opposition shall not be deemed to have been filed until the opposition fee has been paid. (Art. 99(1) European Patent Convention).